

LUSH-2

Multilayer Polyphonic Synthesizer



User Manual

Requirements

Software and hardware requirements:



Windows PC

OS version	Windows 7 or newer
CPU	Intel x86 / AMD x86
Software	VST2 / VST3 /AAX compatible host application (32bit or 64bit)



Apple Mac

OS version	OS X 10.13 or newer
CPU	Intel x86 / Apple Silicon
RAM	8 GB (16 GB Recommended)
Software	AU / VST2 / VST3 / AAX compatible host application (64bit!)

Hardware requirements / recommendations are based on estimates performed on available computers at D16 Group HQ, and therefore cannot cover all possible configurations available on the market. CPU usage may vary widely depending on the manner in which the product is used. Factors that may contribute to variance in CPU usage include particular patch and its complexity, the global quality setting, project sample rate. In order to form a better understanding of how a plug-in will behave within your current setup, we highly recommend downloading the demo and giving it a try.

Preliminary information

This chapter contains general advice for using the plug-in's interface.

To do a right-click on macOS with single button mice:

Either use your **mouse click** while holding the **CTRL key** on your keyboard or use **two fingers** on your **touchpad**.

Checking the value of a parameter

Right-click on any parameter to check its value in its context menu:

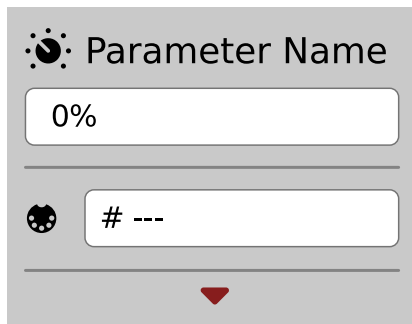

A parameter's context menu

Note: It's currently not possible to enter a precise value in the input box; it's just to check the value.

Fine-tuning continuous parameters

Tweak a control (knob) while holding the **CTRL key** (on **Windows**) or **Apple CMD key** (on **macOS**) - this will make the tweaking more precise while moving the mouse pointer up and down.

Double-click to reset a continuous parameter's value

Double-clicking on a parameter restores its value to the initial state, either default (right after loading the plug-in / loading it along a project file) or from the most recently loaded preset.

Enabling parameters for automation

Lush 2 synthesizer has thousands of sound parameters and VST/AU/AAX host automation allows only a handful of automatable parameters so **by default all parameters are disabled for automation**.

Using the parameter's context menu (described above), you can enable automation for parameters you wish to control externally:

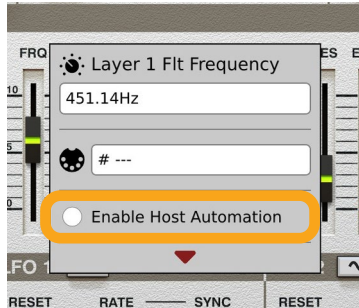

A parameter's context menu

Lush 2 works only with specific sample rate values

Lush 2 works only with the following sample rate values [Hz]:

- 44100
- 48000
- 88200
- 96000
- 192000

If you try to use any other custom sample rate, the plug-in will switch into 44 kHz mode, which may cause it to sound differently or cause audio artifacts to appear.

Introduction to Lush

Lush 2 is a polyphonic subtractive synthesizer. Its structure is based on 8 layers. Each **Layer** is an independent synthesizer with its own parameters and polyphony.

Each of the layers can listen to a different **MIDI** channel and respond to a different keyboard zone. Therefore, the synthesizer works as a multi-timbral instrument where each **Layer** is controlled via a different **MIDI** channel. It is also possible to conveniently split a **MIDI** keyboard into sections, where different **Layers** listen to different keyboard sections of the same **MIDI** channel. You can also create complex sound textures by overlapping **Layers**, where more than one layer listens to the same keyboard zone on the same **MIDI** channel.

Lush 2 allows for convenient mixing of **Layers** within a custom-designed, built-in **Mixer**, where we can add final touches through parametric equalizers, compressors (one per channel) and **3** built-in send effects. Each of the tracks corresponding to one **Layer** or each of **3** available effect tracks corresponding to **3** send effects can be sent to any of **11** available plug-in outputs.

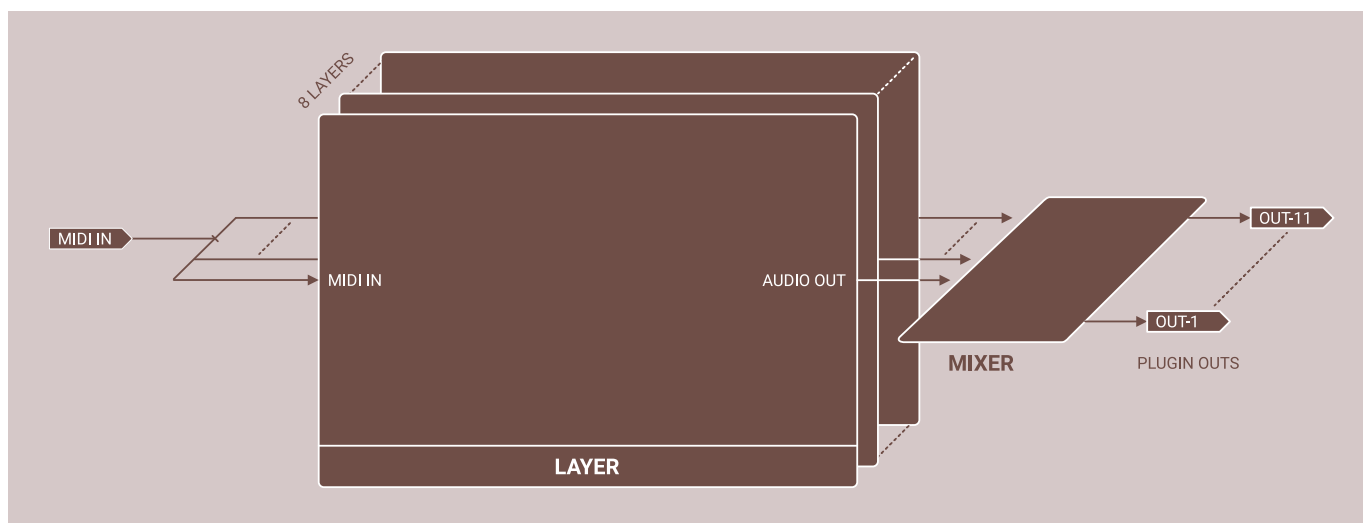

A diagram showing the general signal flow

The plug-in GUI looks as follows:



The Graphical User Interface

At the top of GUI, there is a bar called the **Control** section:



The Control section

And below it, we can see the part of the GUI responsible for editing a single **Layer** (this is the default view, after opening Lush 2 in a host application).



The Synthesis view containing a Layer's parameters

Control section

The **Control** section occupies the top bar of the GUI.

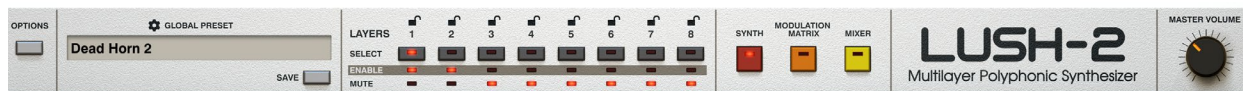

The Control section

In the **Control** section, we can distinguish the following groups of controls:

Options

The **Options** button allows access to an **Options** menu. All plug-in settings can be configured from here.



The Options button

Global preset browser

The **Global Preset** section can load and save **Global Presets** (this preset type is described later) and adjust **Global Preset settings**:



The Preset Management section for Global Presets

Here, we have the following controls:

- **Global Preset** - The text box containing the name of the currently loaded **Global Preset**. Clicking the display opens a browser to load and manage presets (more on that in the **Preset Management** part of the manual).
- **Cog** (icon) - Opens the **Global Preset Settings** window.
- **Save** - Stores current parameter settings of **Lush 2** as a new preset.

Layer selector

The **Layer Selector** contains three rows of buttons to select a **Layer** for editing (first row - **Select**), turn the **Layer** on/off (second row - **Enable**) and mute / solo the **Layer** (third row - **Mute**).

Above this, there is a row of **Padlocks** for locking individual **Layers**, preventing overwrite of selected **Layer** parameters when a **Global Preset** is loaded.

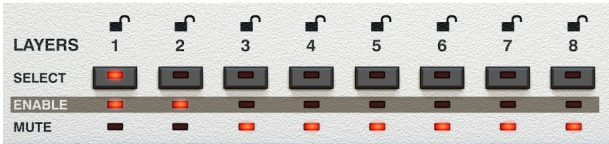

The Layer Selector

View selector

Buttons for switching the **View**:

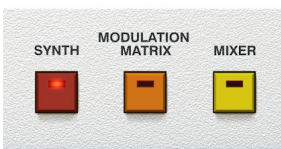

The View (tab) selector

- **Synth** - Edits a selected **Layer's** sound parameters.
- **Modulation Matrix** - Edits a selected **Layer's** modulation matrix.
- **Mixer** - Mixes and combines the sound from all **Layers** together.

Master volume

Master Volume knob - controls the overall volume of the output sound coming from **Lush 2**.

Global preset settings

This panel contains specific settings for the **Global Preset** that are not necessarily at hand when you edit a sound.

Global Preset Settings are stored with a **Global Preset**.

To open the **Global Preset Settings** panel, you need to use the **Cog** icon in the **Global Preset** section on the GUI:



Opening the Global Preset Settings panel

This window will appear:

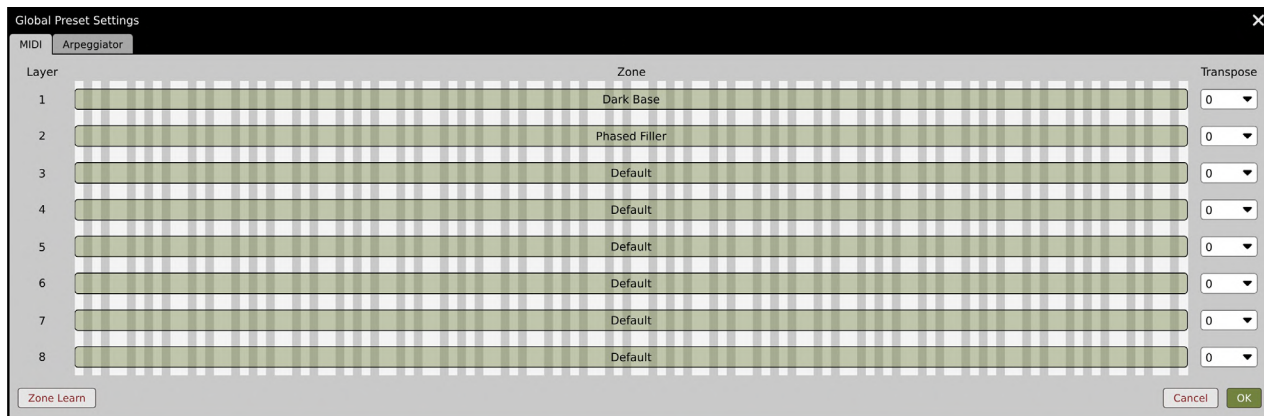

The Global Preset Settings window

Here, you can manage the **MIDI Zones** and transposition (**MIDI tab**), and choose how **Arpeggiators** interact with each other across the **Layers** (**Arpeggiator tab**).

MIDI tab

Zone editor

In the **MIDI tab**, we can easily and conveniently edit which **MIDI zones** different **Layers** will respond to. Each keyboard **Zone** is defined as a complete range between two notes. The lower note defines the beginning and the higher note defines the end of the **Zone**. The **Zone** editor is arranged in rows, where each row represents a single **Layer**.

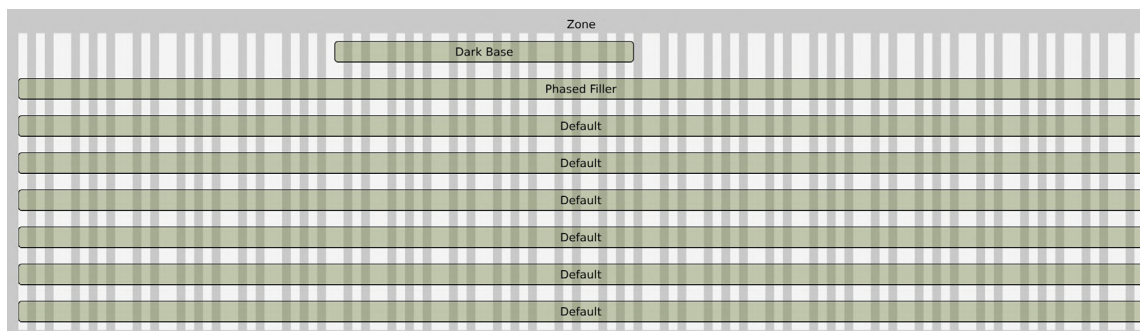

The MIDI Zone editor

When you hover over a zone, two small dots will light up on either side:

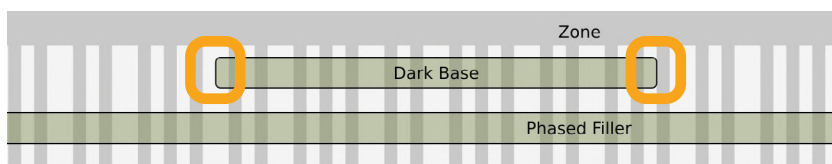

Editing a Zone

You can drag the dots using the mouse pointer and set the beginning or end of each zone.

You can also hold the rectangle in the middle using the mouse pointer and move an entire zone left and right.

Zone learn

Additionally, the **Zone Learn** function is available:

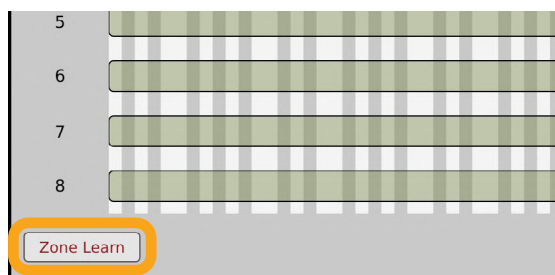

The *Zone Learn* function

We can use it to define a **Zone** directly from the MIDI keyboard:

1. Press the **Zone Learn** button.
2. Click to select a row in the **Zone Editor**, which will turn orange.
3. The plug-in is now ignoring **Channel** settings in **Options**, instead listening to all MIDI channels and waiting for two MIDI note messages.
4. When you press two keys on your MIDI keyboard, either simultaneously or one by one, the plug-in will automatically set the beginning and end of a **Zone**, taking the lower note as the beginning and the higher note as the end.
5. You can repeat steps 2 – 4 if you want to set up MIDI **Zones** for more than one **Layer**.
6. Press **Zone Learn** again to deactivate the function.

Transposition

Next to the **Zone Editor**, the **Transpose** column can perform transposition for each **Layer**:

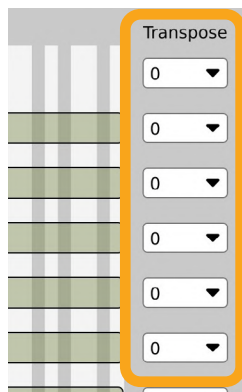

The *Layer Transposition* column

This column lists the **Transposition** parameters from all **Layers** in single place for convenience, so changes here will be reflected as changes in the synthesis view also:

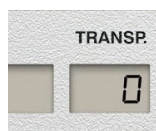

The *Layer transposition* parameter

Arpeggiator tab

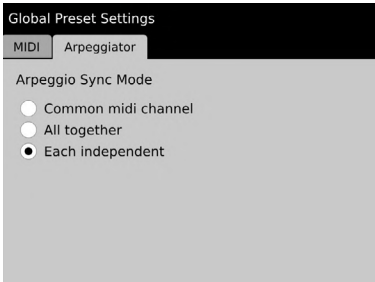

The Arpeggiator tab - Global Preset Settings

This section contains only one setting: **Arpeggio Sync Mode**.

If we use the **Arpeggiator** on more than one **Layer**, **Arpeggio Sync Mode** defines how the **Arpeggiators** communicate or synchronize across **Layers**. The timers for **Arpeggiators** in **Layers** can work independently or together according to specific criteria. If the timers of two or more

Arpeggiators are joined together, the first **Arpeggiator** triggered (*Master*) generates a master timing signal simultaneously while generating its sequence of notes. The other **Arpeggiators** will be synchronized to this. In other words, subsequent triggered **Arpeggiators** (*Slave*) will generate a note sequence(s) quantized / synchronized with a timing signal generated by the **Master Arpeggiator**. **Arpeggio Sync Mode** defines the criterion by which **Arpeggiators** in **Layers** are grouped together. Within a single group, the first **Arpeggiator** triggered becomes the *Master*. We can select one of the following criteria:

- **Common MIDI Channel** - **Arpeggiators** set on the same MIDI channel (**Options** panel) are grouped together and the first triggered **Arpeggiator** synchronizes other **Arpeggiators** in the group. Any two **Arpeggiators** in different **Layers** listening to the same MIDI channel are grouped together and one of them becomes a *Master*. Any two **Arpeggiators** in **Layers** listening to different MIDI channels will be in separate groups.
- **All together** - All 8 **Arpeggiators** (from all 8 **Layers**) are grouped together; when one of them is triggered, the other **Arpeggiators** adjust their timers to the first.
- **Each independent** - All **Arpeggiators** work completely independently and none affect the others.

Layer parameters

We access **Layer** parameters by clicking the **Synth** button in the **Control** section:

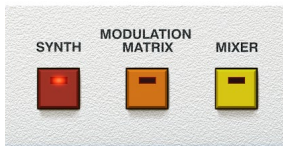

The View (tab) selector

They are displayed in the main part of GUI:



The Synthesis view, containing a Layer's parameters

From the 8 available, we can select the **Layer** we want to edit using the **Layer** selection buttons in the **Control** section:

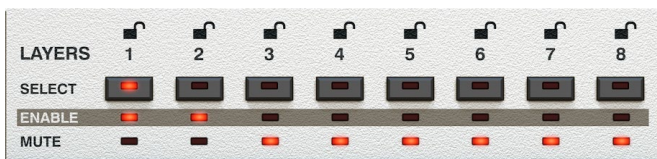

The Layer selector

In a single **Layer**, we can distinguish between the following groups of controls:

- **Layer [No.]** - Browse presets for individual **Layers** and transpose them



The Layer Presets browser

- **Voices** - Polyphony management



The Voices section

- **FX Rack** - For processing the **Layer's** outgoing signal through two insert effects



The FX Rack section

- **Layer Out** - To make final touches before the signal goes into the **Mixer**



The Layer master

- A set of sound parameters to generate the sound

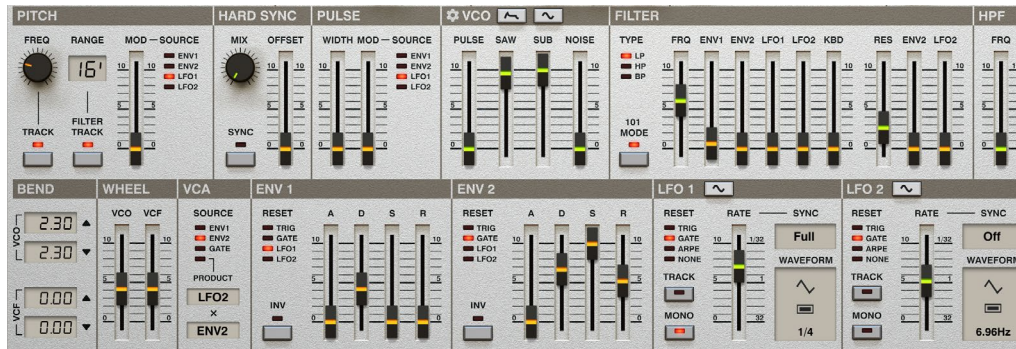

The Layer's sound parameters

- **Arpeggiator** - A set of parameters controlling the **Layer's** Arpeggiator



The Layer's sound parameters

The layer's top bar

At the top of **Layer** parameters, you will find this section:



The Layer control parameters

You can find there:

Layer preset browser

The **Layer Preset Browser** section:



The Layer Preset Browser

Presets in **Lush 2** can be created and stored on a few levels of hierarchy, either for specific groups of parameters or for all parameters; they can be created for a single **Layer** or for a combination of all **8 Layers**, and they can also be created for additional parameters such as **Mixer** send settings. Single **Layer** presets are called **Layer Presets** and presets for a combination of **Layers** are called **Global Presets**, and because these are stored in hierarchy, a **Global Preset** can load up **Layer Presets** within it.

In the **Layer Preset Browser** section, we have the following controls:

- **Preset** - The text box containing the name of the currently loaded **Layer Preset**. Clicking the display opens a browser to load, save and manage presets (more on that in the **Preset Management** part of the manual).
- **Copy** (icon) - Copies parameters from the currently selected **Layer** into a buffer.
- **Paste** (icon) - Pastes parameters from the buffer onto a selected **Layer**.

Layer transposition

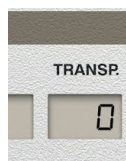

The Layer's transposition setting

This allows for transposing a layer by **24 half-tones** up or down in 1 half-tone steps.

Polyphony and unison

Polyphony settings

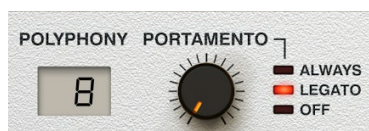

Voices - Polyphony settings

In this section, we can edit **Polyphony** and **Portamento** settings for the **Layer**:

- **Polyphony** - Choose up to 32 voices of **Polyphony** for the selected **Layer**. If the number of voices is equal to 1 then the **Layer** will play in **Mono** mode.
- **Portamento** - Only available with **Mono** mode (**Polyphony** = 1). Turn the knob to control **Portamento** time, which is the time of smooth pitch slide between two successive notes. The radio group to the right controls the **Portamento** mode and it has three values:
 - **Off** - **Portamento** is off.
 - **Always** - **Portamento** is always on (for overlapping and non-overlapping MIDI notes).
 - **Legato** - **Portamento** works only for overlapping MIDI notes.

Unison



Voices - Unison settings

Unison mode makes the **Layer** play a single note with a few voices of **Polyphony** at the same time, in which each voice has slightly varied settings (for **Tune**, **Panorama** and/or its **Filter's** cutoff). By default, **Unison** mode is turned off (value of **Unison** at 1). Increasing the value of the **Unison** LED display turns on **Unison**, and the **Spread** knobs become active.

- **Tune** - The volume of detuned voices in **Unison**.
- **Pan** - The spread of voices in **Unison**.
- **Filter** - The strength of **Filter** cutoff spread among the voices of **Unison**.

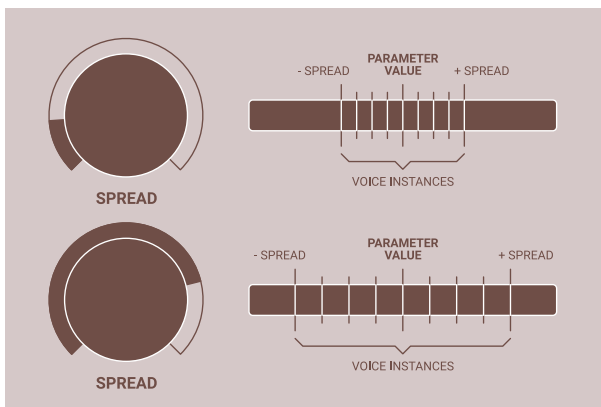

A Unison spread diagram

Please note that **Unison** mode “steals” **Polyphony**, e.g. when we set **Unison** to 2, we will not be able to set the polyphony greater than 16 because it would exceed 32 voices in total (**Unison** voices multiplied by **Polyphony**).

Voice settings

Clicking the **Cog** icon next to the **Voices** label...



Accessing Voice settings panel

... allows access to the **Voice settings** panel.

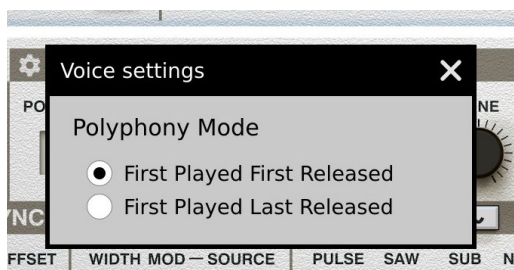

Voice settings panel

Polyphony mode - Polyphony for the Layer is limited by the number of voices allocated; if Polyphony is too small then previously played and sustained sounds will be stopped by new incoming MIDI notes. This will be most noticeable for sustained phrases and/or for sounds with longer release times. In **Lush 2**, we can choose how notes should be distributed among available voices of polyphony; that is to say, the order in which voices should be assigned to incoming notes and later released. There are two modes built-in:

- **First played first released** - (Default value) This is analogous to a queue of notes where the first note in a sustained sequence will be also the first one released - a method inspired by Korg's analogue synthesizers.
- **First played last released** - Voices management is done in a way similar to a stack, where the note previous to any new note will be the first released - this method was inspired by Roland's analogue synthesizers.

Sound synthesis

Lush 2 is a subtractive synthesizer and the signal flow control does not differ substantially from most compact hardware or software synthesizers on the market. It encompasses all the elements and components widely used in modern synthesizers.

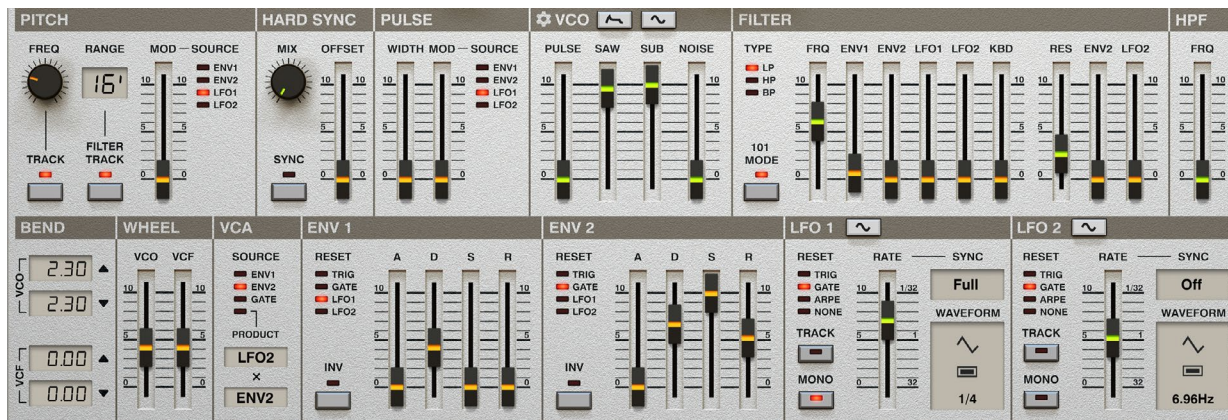

The Synthesis parameters

Oscillators

Lush 2 has four oscillators:

- **Square** with adjustable pulse width and a **Hard Sync** option.
- **Sawtooth** with **Hard Sync** and **SuperSaw** options.
Note: The supersaw oscillator mixes a few sawtooth waveforms together, each slightly detuned.
- **Suboscillator** with 5 different waveforms to select from.
- **Noise** generator with three different colors to select from.

Oscillators mixer

Oscillators can be mixed together proportionally, set by sliders placed in the Voltage Controlled Oscillator (VCO) section:



Synthesis - VCO mixer

Starting from the left side, sliders in this section are responsible for:

- Volume of Square oscillator with adjustable pulse width
- Volume of Sawtooth oscillator
- Volume of Suboscillator
- Volume of Noise generator

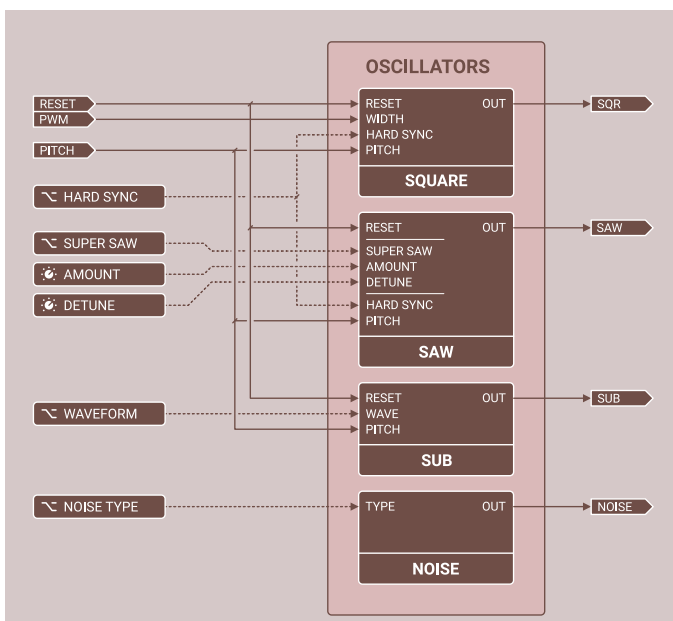

A VCO diagram

Oscillator's independent Voltage Controlled Amplifier (VCA)

Clicking the **Envelope** icon in the **VCO** section:

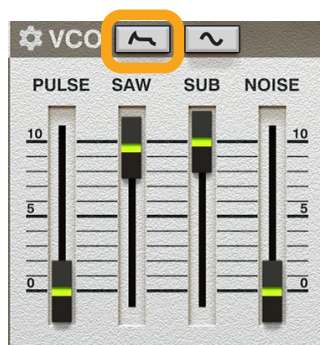

Accessing the Independent VCA

We get access to the **Independent VCA** panel.

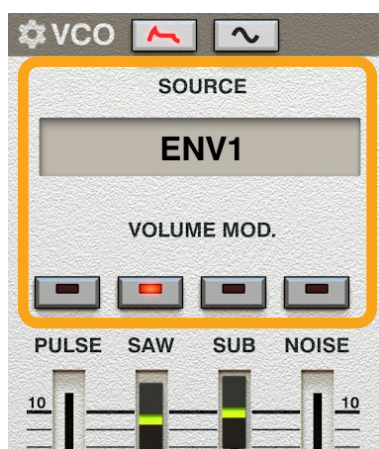

An individual VCA panel

It's possible to modulate the volume of individual oscillators with a modulation **Source**; the source browser box above the oscillator faders allows you to choose one of either two available **Envelopes** or two available **LFOs**. The **Volume Mod** buttons below it select which oscillators should be affected.

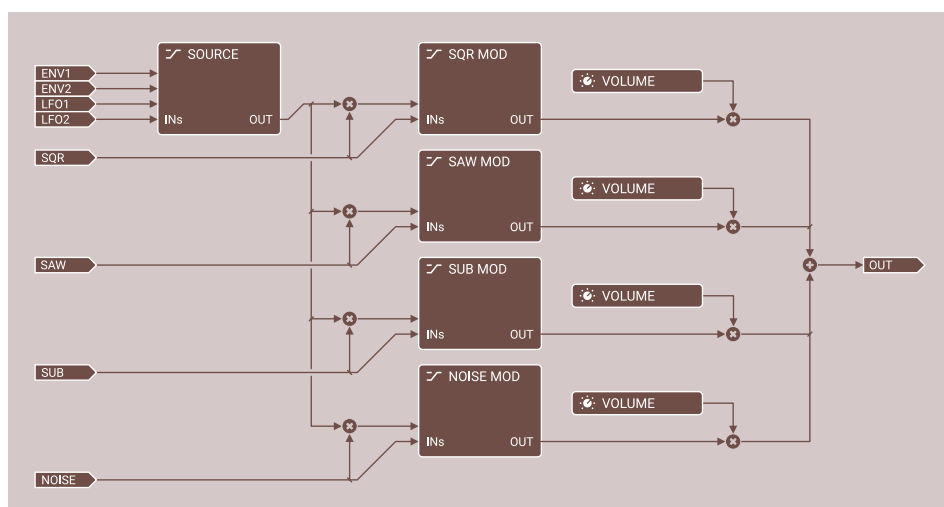

A diagram showing the oscillators' independent amplitude modulation by selected Source

The oscillators' waveform options

Clicking the sine wave icon in the VCO section:



Accessing the VCO modifiers panel

We get access to the **VCO Waveform Options** panel.



The VCO modifiers panel

SuperSaw

The **SuperSaw** mode is controlled by one button and two knobs.



SuperSaw mode

- **Super** - Activates and deactivates SuperSaw mode and the following parameters:
- **Amt** - Sets the effect strength; the bigger the value is, the more saw oscillators are added.
- **Detune** - Sets the detune value between additional saw oscillators.

*Note: Please note that **SuperSaw** and **Hard Sync** cannot work simultaneously. If you turn on **Hard Sync** mode, **SuperSaw** will be automatically disabled.*

SuperSaw is a function of the **Sawtooth** oscillator, therefore the amplitude of **SuperSaw** is controlled by **Sawtooth's** volume fader in the **VCO** section.



The VCO's sawtooth volume

Suboscillator waveform

The **Wave** display:



The Suboscillator's waveform

This chooses one of the five available waveforms for the **Suboscillator**:

- **Square** with 50 / 50 pulse width, **one octave below** base frequency
- **Sawtooth**, **one octave below** base frequency
- **Square** with 50 / 50 pulse width, **two octaves below** base frequency
- **Sawtooth**, **two octaves below** base frequency
- **Square** with 25 / 75 pulse width, **two octaves below** base frequency

Noise type

The **Type** display:



The Noise type selector

This selects from the following noise types for the **Noise** generator:

- **White**
- **Pink**
- **Brown**

Oscillators' hard restart option



Oscillators' hard restart

The **Osc Reset** (*Oscillators Hard Restart*) option is turned off by default. If activated, a given **Layer's** oscillators' phases (**VCO**) are reset each time a new note is played. The **Legato** (overlapping notes) in monophonic mode is an exception, where a new incoming note does not reset oscillator phases, even with **OSC Reset** activated.

VCO settings

Clicking the **Cog** icon next to the **VCO** label, you can access the **VCO Settings** panel.

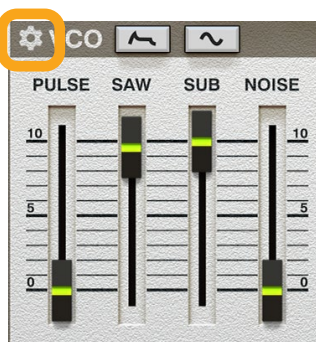

The Cog icon in the VCO section

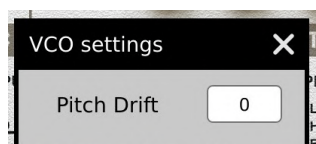

The VCO settings panel

From here, you can control the **Pitch Drift** option, which is a random, wandering pitch change that affects each oscillator independently. It gives the characteristic of an unstable vintage analog synth. The greater the value, the bigger the drift; a value of 0 (default) means no drift at all.

Pulse width modulation

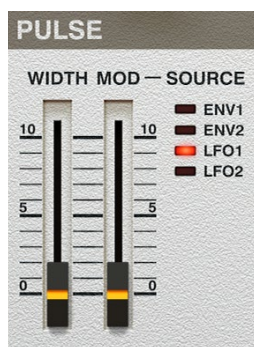

The Pulse section

The three parameters in the **Pulse** section are responsible for controlling the pulse width of the first oscillator in the **VCO** section:

- **Width** - Controls the pulse width of the square wave.
- **Mod** - Decides the amount of pulse width modulation by a modulation source.
- **Source** - Selects the modulation source: **LFO1**, **LFO2**, **ENV1**, **ENV2**.

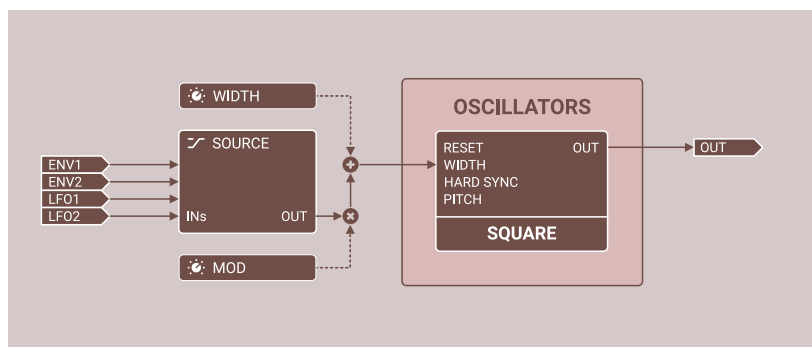

A PWM diagram

Hard sync

Usually, **Hard Sync** requires two oscillators; one of them restarts the period of the second one. The **Master** oscillator has a constant frequency based only on a MIDI note's frequency; the **Slave** oscillator has a frequency based on note frequency, varied by additional modulation sources (like **Envelope** or **LFO**). In **Hard Sync** mode, the **Master** oscillator, as it reaches the end of its phase, also restarts the **Slave** oscillator's phase. In **Lush 2**, **Hard Sync** is achieved using a second hidden oscillator for **Pulse** and **Sawtooth** generators. **Hard Sync** can be controlled and activated in the **Hard Sync** section of the GUI.



The Hard Sync section

- **Sync** - Activates and deactivates **Hard Sync**.
- **Offset** - Decides frequency offset of the slave oscillator.
- **Mix** - Crossfades between the **Slave** oscillator, and the mixed **50 / 50 Slave and Master** oscillators.

When **Hard Sync** is enabled, the pitch modulation (**Mod fader** in **Pitch** section) affects the **Slave's** oscillator frequency only.

Envelope generators - ENV1 and ENV2

Envelopes can be used for controlling the signal amplitude, filters, sound pitch or pulse width. We have two generators at our disposal in the **Layer** parameters section. Their controls are located in sections: **ENV1** and **ENV2**.

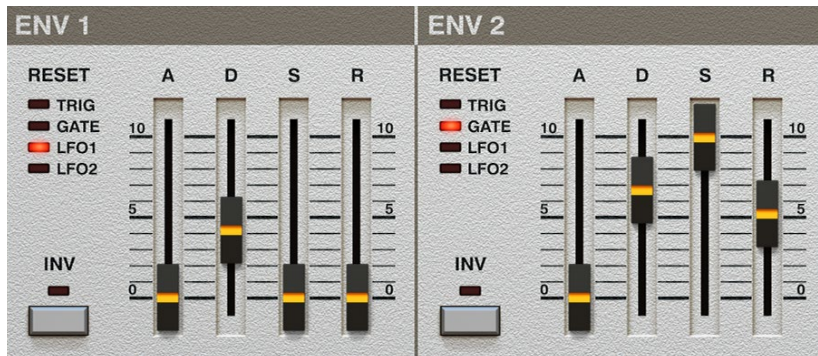

ENV1 and ENV2 sections

These are classic **ADSR** generators with four parameters:

- **A** - Attack time
- **D** - Decay time
- **S** - Sustain level
- **R** - Release time

There are two additional parameters:

- **Reset**
- **Invert**

Reset

This parameter decides when the **Envelope** is re-triggered.

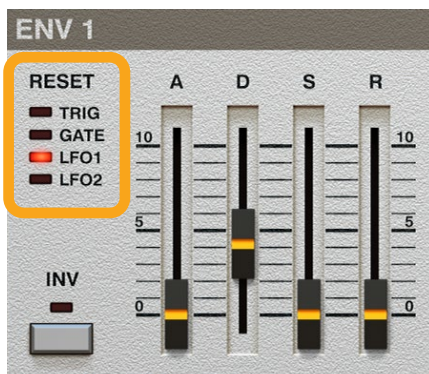

The Reset parameter

We have the following values to choose from:

- **Trig** - Each incoming note to **Lush 2** re-triggers the **Envelope**.
- **Gate** - A note re-triggers the **Envelope** if no other note is currently playing. Therefore, overlapping notes do not re-trigger (**Mono** only).
- **LFO1** - The **Envelope** is re-triggered when a new period of **LFO1** starts.
- **LFO2** - The **Envelope** is re-triggered when a new period of **LFO2** starts.

Trig and **Gate** affect played notes differently in **Mono** mode (**Polyphony** = 1); however, in **Poly** mode (**Polyphony** > 1) there is no difference between the practical operation of **Trig** and **Gate**.

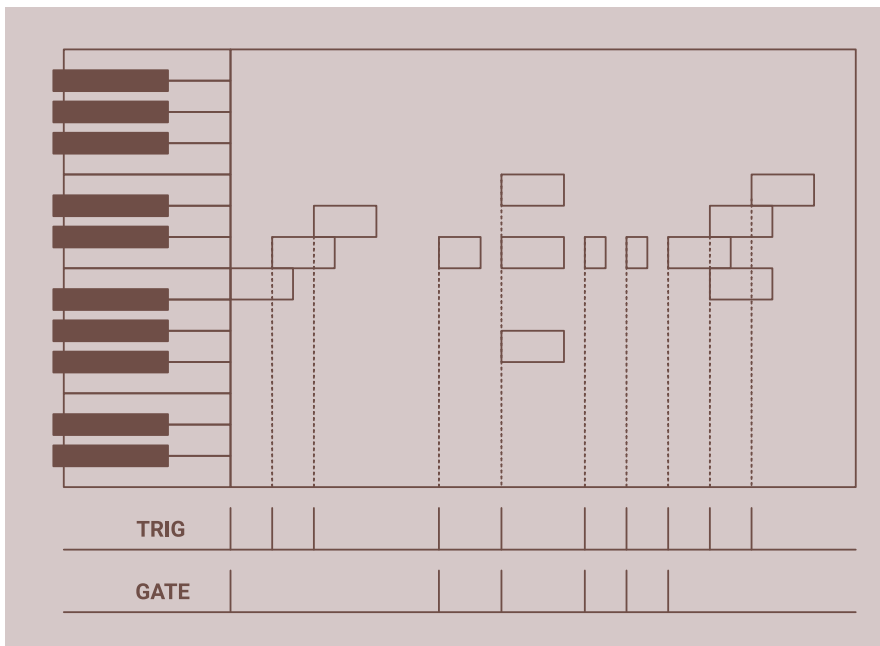

A diagram demonstrating the retriggering of an Envelope

Invert

The **Envelope** can be inverted on its y-axis using the **Invert** option.

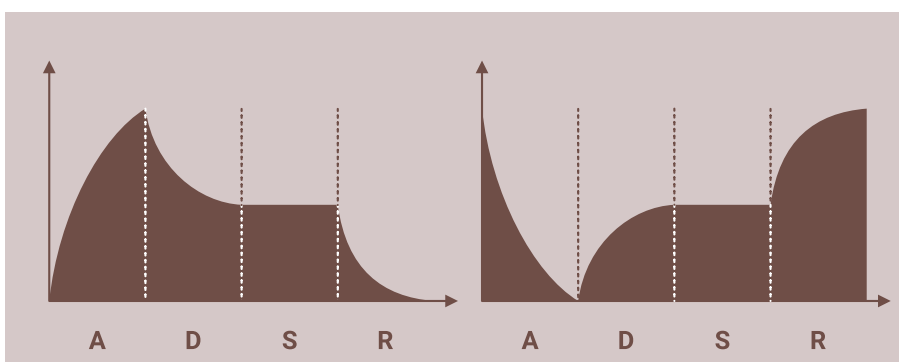

A diagram for positive (straight) and negative (inverted) envelopes

Depending on the **Invert** button's state, the envelopes are straight or inverted.

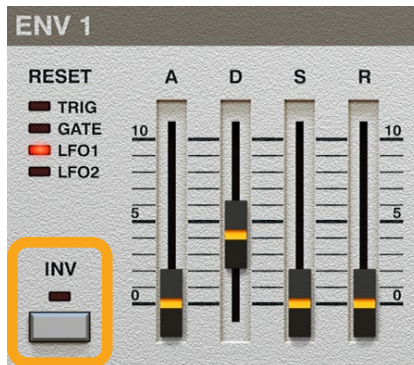

The envelope's Invert button

LFO1 and LFO2

In the **Layer** parameters section, there are two multipurpose *Low Frequency Oscillators*, with control parameters for each located in sections **LFO1** and **LFO2** of the GUI:

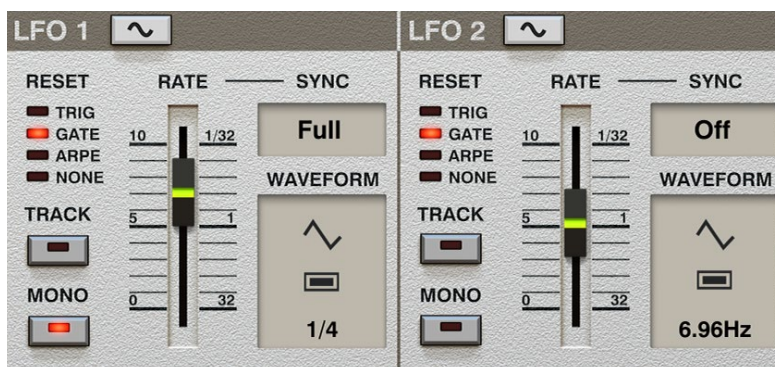

LFO1 and LFO2 sections

Both **LFOs** can be used for controlling sound pitch, filter parameters, pulse width or sound amplitude. There are two main parameters for an **LFO**:

- **Waveform** - Clicking the display we can choose one of 5 available waveforms:
 - Triangle
 - Square
 - Sawtooth
 - Random
 - Noise
- **Rate** - Defines the frequency of the **LFO**, except for the **Noise** waveform which isn't affected by frequency.

Further parameters controlling the **LFO** work mode:

- **Reset** - Decides what conditions reset the **LFO** (set on the beginning of each period) - see the next manual section for details.
- **Sync** - (Tempo synchronization) Selects an **LFO's** synchronization with the tempo. By default, the **LFO** is internally timed (**Sync** is set to off). When we set **Sync** to any other value, the frequency of the **LFO** will depend on the tempo set in a host application and the **Rate** becomes a discrete parameter that sets the rate relative to the tempo, in notation values.
- **Track** (Keyboard tracking) - Lets the frequency of the note affect the **LFO** frequency when turned on. With this feature, we can achieve a simple FM synthesis (modulating a frequency of **VCO** with an **LFO**).
- **Mono** (mode) - (Turned off by default) In **Poly** mode with **Mono** switched on, all voices in the **Layer** have **LFOs** synchronized together in phase, giving the impression of a single **LFO** controlling all **Layer** voices at once.

Tempo synchronization

By default, the **Sync** parameter is set to **Off**.



An LFO's Sync parameter

With **Sync** set to off, the **LFO's Rate** is expressed in Hz (tempo independent units). If you set the **Sync** parameter to any other value, the **Rate** will be expressed in notation values relative to the host application tempo: **32, 16, 8, 4, 2, 1 bars, 1/2, 1/4, 1/8, 1/16 and 1/32**, and the **Sync** parameter will select the rhythmic modifier for the **Rate**:

- **Full** note
- **Dotted** note
- **Triplet** note

Reset

The **Reset** parameter decides what conditions reset the **LFO** (set on the beginning of each period).



An LFO's Reset section

We have 4 possibilities:

- **Trig** - Each new incoming note resets the **LFO**.
- **Gate** - Incoming note resets the **LFO** if no other note is currently being sustained in incoming MIDI (**Mono** only).
- **Arpe** - This works only when the **Arpeggiator** is active. The **LFO** is reset when the **Arpeggiator** starts generating a sequence, i.e. when we release all the keys on the MIDI keyboard and press them (or one of them) again.
- **None** - The **LFO** does not reset.

In **Poly** mode (**Polyphony** > 1), the behavior of **Trig** or **Gate** is the same, because in both cases the **LFO** is reset for every incoming note.

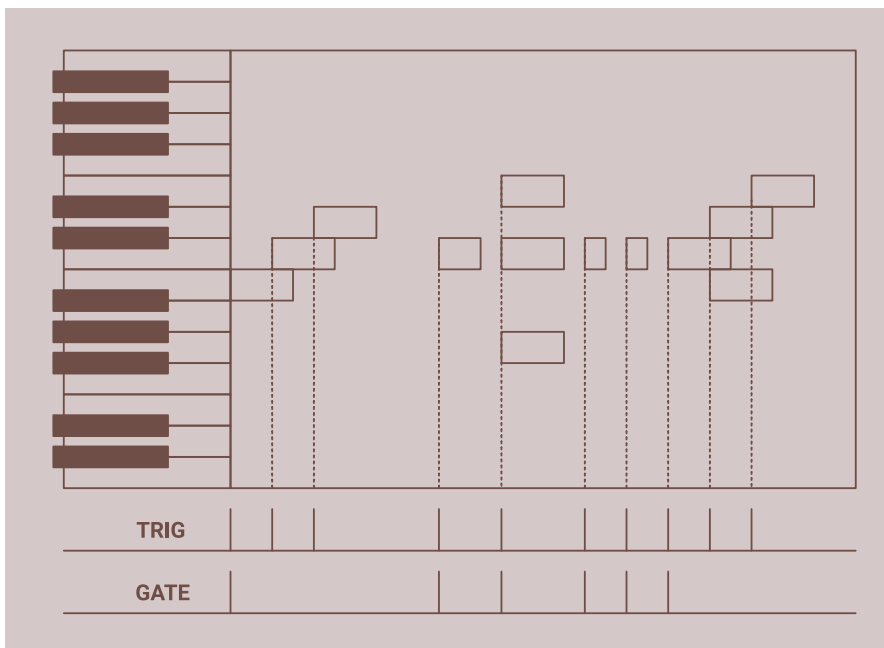

A diagram demonstrating the retriggering of an LFO

Extra parameters

Clicking the **Wave** icon or **Waveform** display, we get access to an **LFO's** additional parameters:



Accessing an LFO's extra parameters

Once we open the panel, here's what we see:



An LFO's extra parameters

We can adjust the LFO with the following controls:

- **Waveform** - Clicking the display, we can choose one of 5 available waveforms:
 - Triangle
 - Square
 - Sawtooth
 - Random
 - Noise
- **Invert** - Inverts the LFO's waveform.
- **Phase** - Adjusts the LFO's phase shift from 0 to 360 degrees.

Filters

Lush 2 has two serially connected filters.

- The first is a multi-mode resonant filter (**Low-pass**, **Band-pass** and **High-pass**).
- The second is a **High-pass** filter with a characteristic **RC** analogue filter.

In the **HPF** section, we have only one parameter and this controls the second of those two filters (**High-pass**); **FRQ** – the cutoff frequency of the **High-pass** filter.



The High-pass filter

In the **Filter** section, we have access to parameters that control the multi-mode resonant filter:

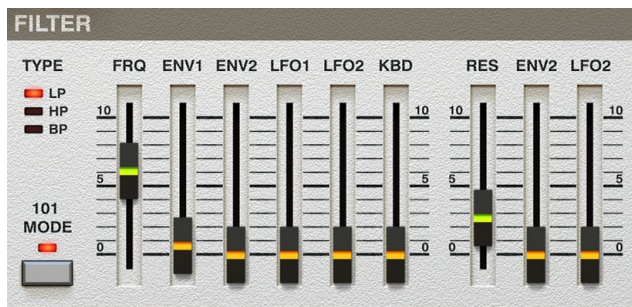

The multi-mode resonant Voltage Controlled Filter (VCF)

From the left, respectively:

- **Type** - We have three available filter types to select from:
 - **LP** - Low-pass,
 - **BP** - Band-pass,
 - **HP** - High-pass.
- **101 Mode** - When disabled, the overall peak volume of the filter output is constant across the **Cutoff Frequency** and **Resonance** domain and the **Filter** itself is softer in comparison to *SH-101* characteristics. When enabled, the **Filter** is more unstable and analogue, like with faithful emulation of self-oscillations appearing in *SH-101*.
- **FRQ** - Sets the filter cutoff frequency.
- **ENV1** - Sets the depth of modulation for the cutoff frequency by **Envelope 1**.
- **ENV2** - Sets the depth of modulation for the cutoff frequency by **Envelope 2**.
- **LFO1** - Sets the depth of modulation for the cutoff frequency by **LFO1**.
- **LFO2** - Sets the depth of modulation for the cutoff frequency by **LFO2**.
- **KBD** - (Keyboard tracking) Applies **Pitch** frequency on the **Cutoff** frequency of the filter. The **KBD** parameter controls the amount of this effect. When the **KBD** is set to minimum, the cutoff frequency remains unchanged in relation to **VCO** frequency, causing higher notes to be duller with the low pass filter turned on. When the **KBD** is set to maximum, the cutoff frequency is perfectly tuned with the **VCO's Pitch**, tracking the pitch exactly; the brightness of the sound will stay the same throughout the keyboard range.
- **RES** - Sets filter resonance level.
- **ENV2** - Sets the depth of modulation for resonance level by **Envelope 2**.
- **LFO2** - Sets the depth of modulation for resonance level by **LFO2**.

The diagram below shows the manner in which parameters from the **Filter**, **Bend + Wheel** and the **Pitch** sections affect the **Filter**:

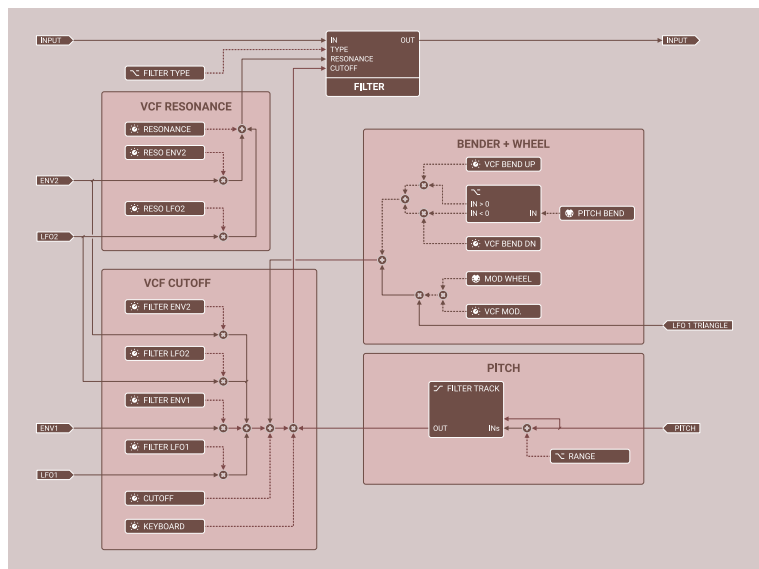

A Filter diagram

Pitch parameters and modulation

In the **Pitch** section on the GUI, we have a set of parameters that control the influence of the **Envelopes** or **LFOs** on the frequency of oscillator in the **VCO** section.



The Pitch section

Starting from the left, the first two parameters control pitch tracking:

- **Freq** - Sets the absolute frequency of the **VCO** (from 20 Hz to 8 kHz); this parameter works only when **Track** is turned off (described below).
- **Track** - (Turned on by default) Takes the pitch of incoming midi notes into account when a sound is generated. If we turn off the **Track**, the pitch of incoming midi notes is ignored by **Lush 2** and the frequency is constant (controlled by the **Freq** parameter). In consequence, no matter what key we press on the keyboard, the sound will have exactly the same frequency.

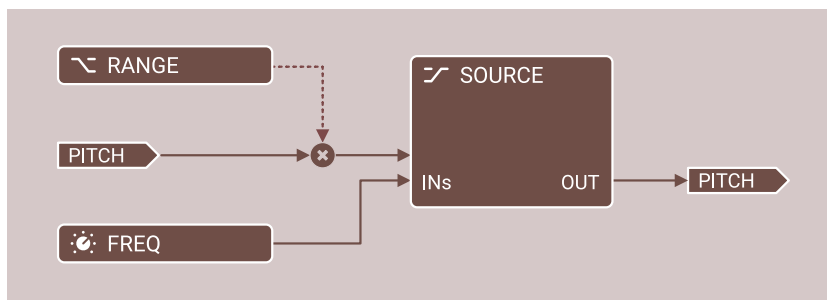

A pitch frequency tracking diagram

Next, we have a column with another two parameters:

- **Range** - Pitch transposition by whole octaves:
 - **16'** - Pitch not transposed.
 - **8'** - Pitch transposed by +1 octave.
 - **4'** - Pitch transposed by +2 octaves.
 - **2'** - Pitch transposed by +3 octaves.
- **Filter Track** - Sets the filter keyboard tracking to take **Range** and **Freq** (when **Track** is turned off) into account when active.

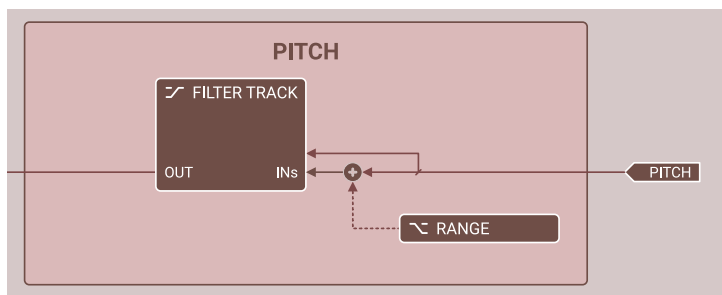

A diagram showing filter track effect on the filter

Amplitude modulation - VCA

The VCA section selects the way amplitude is modulated.

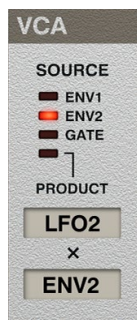

The VCA section

The **Source** switch is responsible for selecting the generator:

- **ENV1** - Selects **ENV1** to control sound amplitude.
- **ENV2** - Selects **ENV2** to control sound amplitude .
- **Gate** - Selects the **Gate** signal to control sound amplitude, i.e. an incoming MIDI Note On message generates positive slope (sound amplitude has maximum value) and MIDI Note Off message generates negative slope (sound amplitude is zero).
- **Product** - Selects the product of two modulators to control sound amplitude. We can select which modulators are used in the displays below:



Product sources

Each display allows you to select one of the following modulators: **LFO1**, **LFO2**, **ENV1**, **ENV2**.

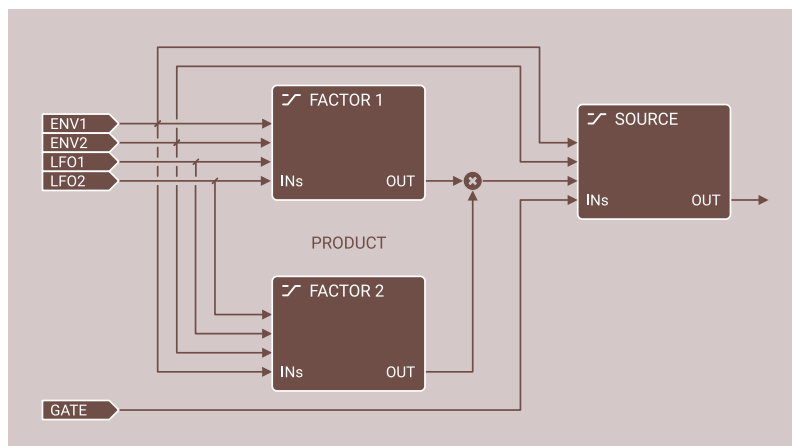

A VCA amplitude modulation diagram

Wheel and bend sections

These two sections allow you to change the effect of the modulation wheel and/or pitch bender on the filter's and/or oscillator's frequencies.



The Wheel and Bend sections

- Bend** - Sets the *pitch bender* to control the oscillator's frequency and/or filter cutoff frequency. There are two parameters:
 - VCO** - Sets the range across which the *pitch bender* will affect the oscillator's frequency (independently for bender up and down positions, expressed in *half-tones.cents*).
 - VCF** - Sets the range across which the *pitch bender* will affect the filter cutoff frequency (independently for bender up and down positions, expressed in *half-tones.cents*).
- Wheel** - Allows the *modulation wheel* to control the depth of effect of **LFO1** on the oscillator frequency and/or filter cutoff frequency. We have the following parameters:
 - VCO** - Sets the depth of modulation for the oscillator's frequency by **LFO1's** output - gives a vibrato effect controlled by the modulation wheel.
 - VCF** - Sets the depth of modulation for the filter frequency by **LFO1's** output.

Note: Please note that the **Waveform** of the **LFO1** output for the wheel section is always **triangular**. The **Waveform** parameter in the **LFO1** section is ignored here.

The diagram below presents the manner in which **VCO** parameters in **Bend** and **Wheel** sections influence the oscillator frequency:

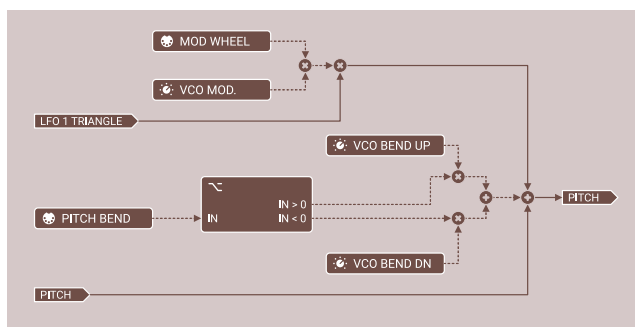

A diagram showing how wheel and bender affect VCO parameters

This diagram presents the way **VCF** parameters in **Bend** and **Wheel** sections affect the filter cutoff frequency:

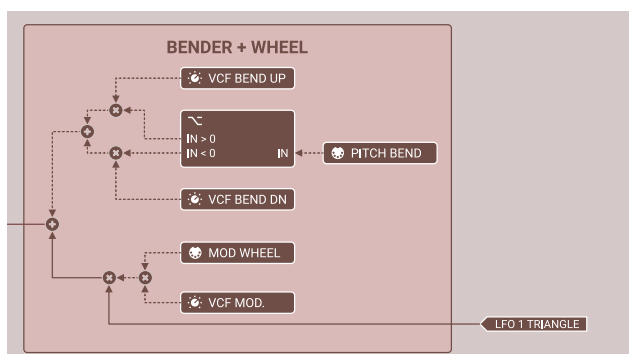

A diagram showing the effects of wheel and bender in the filter section

Insert effects

Two insert effects (working in-chain) can be used per **Layer**:



The FX Rack

We are able to select one of the available FX Algorithms:

- Chorus
- Flanger
- String Ensemble
- Phaser
- Vowel Filter
- Distortion
- Decimator
- Tremolo

Or just turn off the insert effect (for **Layer**) - by selecting **None** as an **Algorithm**.

To choose the effect you need, pull down the menu by clicking the **Algorithm** box.

Each of the insert effects has its own set of parameters to control. To access those parameters, pull down the **FX Rack** panel using the button with three dots in the header:



Opening the FX Rack panel

The **FX** knob in each of two insert effects controls the mix between processed and unprocessed signals leaving the effect:



The FX knobs

It's also possible to swap the effect's position in the chain using the swap button in the header:



Swapping insert effect slots

Chorus

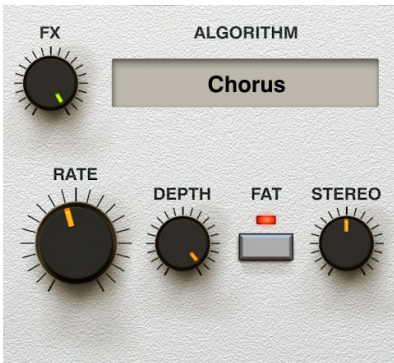

Insert effect - Chorus

- **Rate** - Controls the rate of the LFO for the chorus' delay line.
- **Depth** - Controls the amplitude of the LFO for the delay line.
- **Fat** - Uses a single delay line when disabled. While enabled, another delay line is added to the effect (two delay lines) to get a richer sound.
- **Stereo** - Controls the LFO for the stereo phase shift on delay lines between *left* and *right* channels.

Flanger

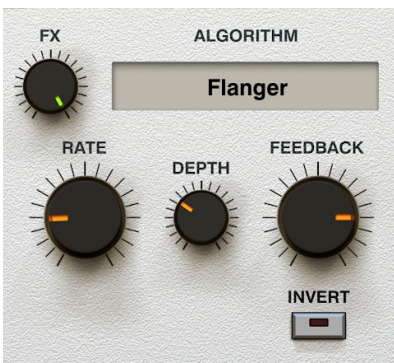

Insert effect - Flanger

- **Rate** - LFO frequency
- **Depth** - Depth of flanger effect
- **Feedback** - Flanger feedback
- **Invert** - Inverts flanger feedback (negative loop instead of positive)

String ensemble

This is a combination of chorus and phaser effects.



Insert effect - String Ensemble

- **String Mode** – Chorus work mode:
 - **Light** – Low depths of **LFOs** controlling delay lines.
 - **Heavy** – High depths of **LFOs** controlling delay lines.
- **Stereo** - Sets phase shift between stereo channels.
- **Phaser** - Turns on/off the **Phaser** in **String Ensemble**.
- **Rate** - Rate of the **Phaser LFO**.
- **Depth** - Amplitude of the **Phaser LFO**.
- **Color** - Turns resonance on and off for the **Phaser** effect.

Phaser



Insert effect - Phaser

- **Rate** - LFO frequency.
- **Depth** - LFO amplitude.
- **Double LFO** - Selects whether the **Phaser** is controlled by one or two **LFOs**. When disabled, the **Phaser** is controlled by a single **LFO** and when enabled, by two **LFOs**. Note that the second **LFO** has constant fixed frequency and lesser amplitude.
- **Stereo** - Stereo phase shift between the channels.
- **Feedback** - Phaser feedback level.

Vowel



Insert effect - Vowel Filter

- **Vowel Stack** - Controls the position of the **Vowel Filter** in a vowel list; the LFO oscillates around this position.

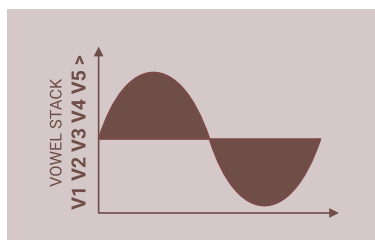

A vowel set diagram

- Above the fader, we see a vowel list with five elements, which can be modified by the user. You can cycle through each vowel element with mouse clicks. Each position can choose between five vowels: A, E, I, O, U.
- **Vocal Tract** - Selects one of the available vocal timbres.
- **Rate** - Sets the frequency of the **LFO** controlling the **Vowel Filter**.
- **Depth** - Sets the depth of the **LFO** controlling the **Vowel Filter**.
- **Reso** - Resonance.

Distortion



Insert effect - Distortion

- **Dynamics** - Sets the amount of compression before distortion. Higher values mean more compression and a less dynamic signal.
- **Preamp** - Sets signal amplification before the clipper.
- **Shape** - Sets the clipping curvature.
- **Threshold** - Sets the threshold value for the clipper.

Bit crusher



Insert effect - Bit Crusher

- **Preamp** - Sets input signal amplification before it is crushed; the parameter ranges between [0 - 48 dB].
- **Resolution** - Decides quantization to a given number of bits [1 - 16]; if the display is set to -- value, the input signal is not quantized and only resampling is performed.
- **Frequency** - Sets the resampling frequency [0 - 44 kHz].
- **AA Filter** - Turns the anti-alias low-pass filter on and off; filter cutoff frequency is linked to the resampling frequency (set by the **Frequency** knob).

Tremolo



Insert effect - Tremolo

- **Waveform** - Selects the tremolo's **LFO** waveform (**Sine** or **Triangle**).
- **Rate** - Sets the rate of the tremolo effect.
- **Depth** - Sets the depth of the tremolo effect.
- **Stereo** - Sets the tremolo stereo phase shift between *Left* and *Right* channels.

Master section

There are three available parameters:



A Layer's master section

- **Fine** - Allows precise (fine) pitch tuning of oscillators in the **Layer**.
- **Volume** - Adjusts **Layer** output volume.
- The **440 Hz** button generates a test signal - a sine wave with **440 Hz** frequency (middle A key).

The **Level** VU meter indicates the **Layer's** output signal level.

Arpeggiator

Lush 2 has a very advanced **Arpeggiator** section. Just like other modules in the **Layer**, this also works independently for each **Layer**. This means that for every **Layer**, the **Arpeggiator** can be activated or not. The **Arpeggiator** section is located on the right side of the **Synth** view.



An Arpeggiator section

In the top area, there is a preset management system for the **Arpeggiator**. You can store your own settings for this section or load prepared ones:



Arpeggiator - Preset Management

Here, we can distinguish the following set of controls:

- **Preset** - Shows the name of the currently loaded preset. Clicking the display opens a browser to load, save and manage presets (more on that in the **Preset Management** part of the manual).
- **Copy** (icon) - Copies parameters from the currently selected **Layer's Arpeggiator** into a buffer.
- **Paste** (icon) - Pastes parameters from the buffer onto the selected **Layer's Arpeggiator**.

The parameters below control the **Arpeggiator**:

- **Rate** - Sets the rhythmical value of a single step in the **Arpeggiator** sequence: **1 bar**, **1/2**, **1/4**, **1/8**, **1/16**, **1/32** and **1/64**. Additionally, with the help of three radio-button LEDs, **Full** / **Dot** / **Tri**, we can modify the rhythmical value of the **Rate** parameter:
 - **Full** - Full note,
 - **Dot** - Dotted note,
 - **Tri** - Triplet.
- **Chords Mode** - When **Chords Mode** is turned off, the **Arpeggiator** behaves regularly (it generates a monophonic sequence accordingly with other settings), but if **Chords Mode** is turned on, the **Arpeggiator** acts as a gater. Pressing a chord on the MIDI keyboard will cause the **Arpeggiator** to play all sounds at once in a single step. *Please note, using the **Chords Mode** requires an adequate polyphony.*
- **Mode** - Selects the **Arpeggiator's** work mode (run mode):
 - **Off** - Arpeggiator turned off.
 - **Up** - Upward sequencing.
 - **Down** - Downward sequencing.
 - **Up and Down** - Upwards and downwards, beginning from the top of the sequence.
 - **Down and Up** - Downwards and upwards, beginning from the bottom of the sequence.
 - **Random** - Random order sequencing.
 - **Manual** - Sequencing according to the order of keys pressed on the MIDI keyboard.
- **Octaves** - **Arpeggiator** range expressed in octaves.
- **Repeat** - Number of repetitions of the **Arpeggiator** sequence in each octave.

- **Hold Mode** - Typically, **Hold Mode** causes an **Arpeggiator** sequence to constantly play even if MIDI keys are no longer held on the keyboard. Successively pressed keys will be added to the **Arpeggiator** sequence; in other words, incoming MIDI Note off messages are ignored. In **Lush 2**, we have a few **Hold Modes** to select from:
 - **Toggle** - In this mode, the MIDI keyboard works in **Toggle Mode**; pressing one key adds a corresponding note to the **Arpeggiator's** sequence and pressing the same key once again removes the note from the sequence.
 - **Trigger** - When keys are pressed on the keyboard, their corresponding notes are added to the sequence. When we press and hold, for example, two keys, they are added to a sequence, even if we release one of them, and two notes are still in-queue (playing). Even if we release all pressed keys, the sequence will still play; however, if we press any notes again on the MIDI keyboard, the notes previously played are removed from the sequence, and the new ones pressed will be added to the sequence immediately.
 - **Normal - Hold Mode** works regularly (as described above).
 - **Off - Hold Mode** is inactive.
- **Clear Keys** - Removes all notes from the **Arpeggiator** sequence which were added earlier with **Hold Mode**, irrespective of the chosen **Hold Mode**. Using the **Clear Keys** button while holding CTRL performs the action for all Layers in **Lush 2**.
- **Shuffle** - Sets the swing strength for a generated sequence.
- **Gate** - Sets note length for a single step in a generated sequence. If the **Gate** is set to **100%**, notes generated in an **Arpeggiator** sequence will overlap each other (**Legato**).

In the bottom part of the **Arpeggiator** section there are two rows of LEDs. Each column accords to a single step of the **Arpeggiator** sequence - although that single complete cycle of the **Arpeggiator** can be much longer, because of **Octaves** and **Repeat** values and/or the number of keys pressed on the MIDI keyboard simultaneously.

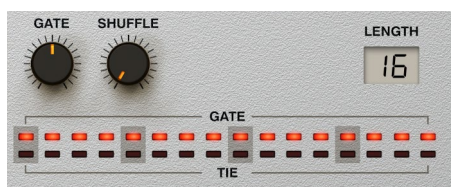

Arpeggiator - Step editor

The 16 LED columns correspond to 16 steps. When the 16th step is reached, the **Arpeggiator** returns to the 1st step. LEDs work in toggle mode, and therefore:

- The first row (**Gate**) displays whether a step is played or not. If an LED is set, the step is played. If an LED is unset, then a pause is generated and the note that should appear in this place is omitted.
- The second row (**Tie**) is used for tying notes together. If an LED is set, the step corresponding to that LED is tied together with the next step. Setting the adjacent LEDs will tie all the notes into a single longer one.

Obviously, the maximum length is 16 steps, but you may decrease it using the **Length** display.

Padlock

There is also a **Padlock** icon in the upper right corner of the Arpeggiator section:

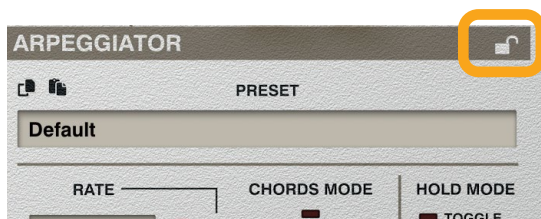

The Arpeggiator's Padlock

It is used for locking all parameters within the **Layer's Arpeggiator**, preventing overwrite of their values when the **Layer Preset** or **Global Preset** is loaded. To read the details, go to the **Preset Management** chapter.

Arpeggiation examples

Let's assume the following values for the **Arpeggiator's** parameters:

- **Octaves** = 1 oct
- **Mode** = Up
- **Repeat** = 1x
- **Rate** = 1/16 (full)

To get an **Arpeggiator** that sounds regularly, we have to set all the LEDs in the **Gate** row and disable all the LEDs in the **Tie** row. For a C-min chord pressed on the MIDI keyboard, the sequence will look as follows:

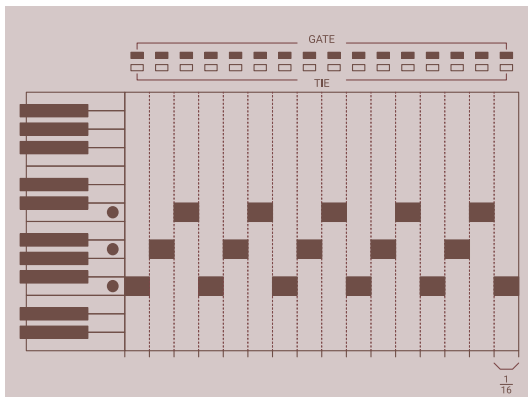

Arpeggiator - example 1 diagram

We can slightly modify the **Gate** row and as a result get the following sequence:

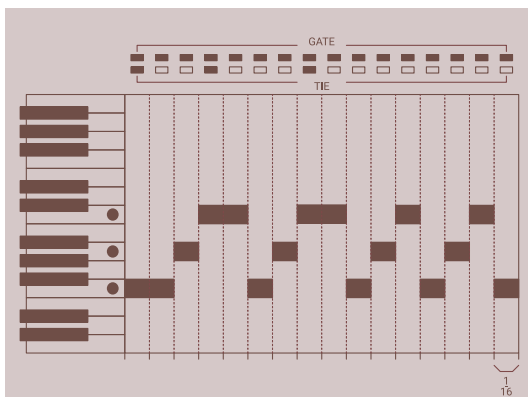

Arpeggiator - example 2 diagram

If we instead slightly modify the **Tie** row, we will receive this sequence:

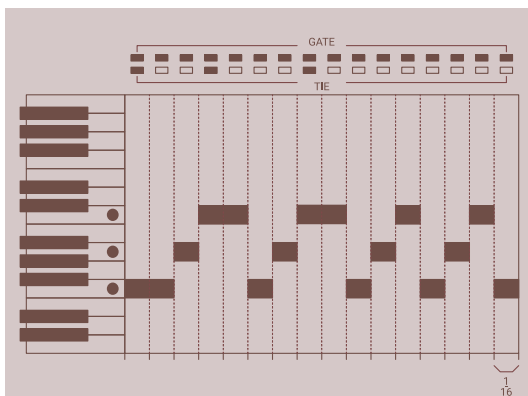

Arpeggiator - example 3 diagram

Modulation matrix

Modulation Matrix is a tool that increases the expressivity of the sound by allowing the user to alter **Layer** sound parameter values using MIDI events. Each **Layer** in **Lush 2** contains its own independent **Modulation Matrix**.

To edit the **Modulation Matrix**, click the **Modulation Matrix** button in the **Select View** section.

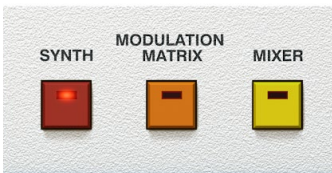

The **Select View** section

After doing so, you will see the **Modulation Matrix** view in the front panel of **Lush 2**:

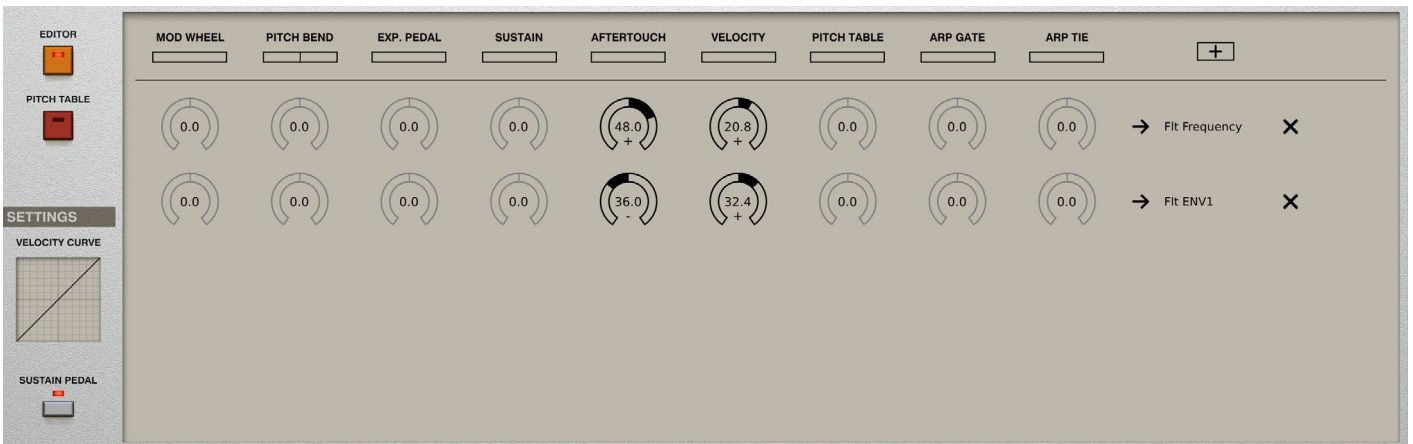

A **Layer's Modulation Matrix**

As you can see, the **Control** section in the top part of the GUI is still visible and accessible, making it possible to switch between **Layers** and edit the **Modulation Matrix** for each without leaving the **Modulation Matrix** view.

The **Modulation Matrix** in **Lush 2** is displayed in a tabular form, in which the following columns can be distinguished:

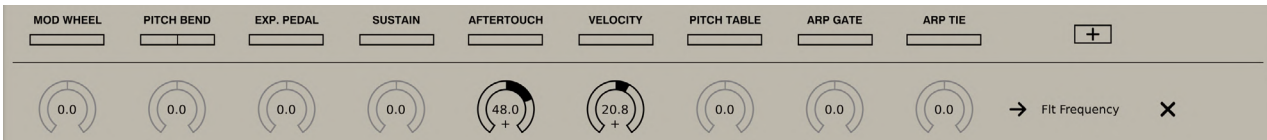

The **Modulation Matrix** row

- **Sources** - Input controllers responsible for modifying the destination parameter. There are 9 modulation sources available starting from the left:
 - **Mod Wheel** - MIDI CC #01 (range [0 - 1]),
 - **Pitch Bend** - MIDI Pitch Bender (range [(-1) - 1]),
 - **Expression Pedal** - MIDI CC #11 (range [0 - 1]),
 - **Sustain Pedal** - MIDI CC #64. Sustain (has one of two values; {0,1}),
 - **Aftertouch** - Or **Channel Pressure**. MIDI Channel Aftertouch (range [0 - 1]),
 - **Velocity** - MIDI Note velocity (range [0 - 1]),

- **Pitch Table** - Values (range [0 - 1]) of **Pitch Table** (see the Pitch Table chapter) assigned to each and every MIDI note,
- **Arp Gate** - **Gate** step sequence from a **Layer's Arpeggiator** (sequence has two-state steps and, because of that sequence, each step can have one of two values; {0,1}),
- **Arp Tie** - **Tie** step sequence from a **Layer's Arpeggiator** (sequence has two-state steps and, because of that sequence, each step can have one of two values; {0,1}).
- **Destination** - The destination parameter to be modified.

Each **Source** -> **Destination** assignment is represented by a user-assignable **Modulation Amount** value ranging from -100% to 100%.



A Modulation Amount dial

Operating a **Modulation Matrix** is based on a formula:

$$\text{Destination} + \text{Source} * \text{Modulation Amount}$$

Where:

- **Destination** and **Source** - Have values (in most cases) in the range of [0 - 1],
- **Modulation Amount** - Has a value within the [-100% - 100%] range scaled down to [0 - 1].

Clicking the **Destination's** parameter name, we can select one of the sound parameters of the **Layer**. Almost all are available to be selected.



Choosing a Destination

It should be remembered that **Velocity** and **Pitch Table** have fewer available **Destination** parameters as they are both source controllers working per voice and some of the **Destination** parameters affect all **Layer** voices (e.g. **Insert Effects** parameters); therefore, **Velocity** and **Pitch Table** sources cannot be assigned to these kind of **Destination** parameters.

To add a new row to the **Modulation Matrix**, use the **Plus** button in the **Destination** column:

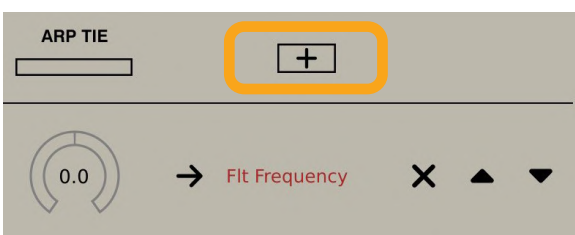

Modulation Matrix - adding a row

To remove a row, use the adjacent **X** button:

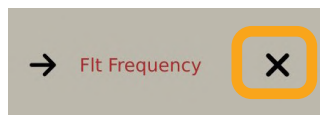

Modulation Matrix - removing a row

When you hover over a row with the mouse pointer, you will see up and down caret icons that you can use to reorder rows:



Modulation Matrix - reordering rows

Voice volume - a special destination parameter

In the **Destination** column, we have a specific parameter available which can be selected, namely **Voice Volume** (almost at the bottom of the pulldown list). This parameter has no equivalent in any of the GUI parameters. It controls the volume of a single voice generated by the synthesizer. Using it as the **Destination** in the **Modulation Matrix** enables a dynamic response between the incoming MIDI velocity and the volume of the plug-in's sound. This parameter works according to a slightly different formula than other **Destinations** in the **Modulation Matrix**. When the **Modulation Amount** value is set to 0, the **Voice Volume** is not modified at all (voices will lack volume dynamics). When **Modulation Amount** is set to 1, the MIDI Note **Velocity** affects the **Voice Volume** to full extent (maximum volume dynamics) in accordance with a principle: the greater the **Velocity** of a MIDI note, the louder the generated sound. But if we set the **Modulation Amount** to -1, then the note **Velocity** is inversely proportional to the sound volume (**Voice Volume**); the greater the velocity value of a MIDI Note, the quieter the sound generated.

Arp gate, arp tie - special modulation sources

In regard to **Sources** in the **Modulation Matrix**, most of them are simply external MIDI events that come in from an active port redirected to **Lush 2**. The **Arp Gate** and the **Arp Tie** are two exceptions to this rule, because they are both generated internally by the **Layer Arpeggiator**. Moreover, these are not continuous parameters but binary sequences generated by the **Arpeggiator** based on the states of **Gate** and **Ties** steps. If the step is set, then the generated value is 1, otherwise it is 0.

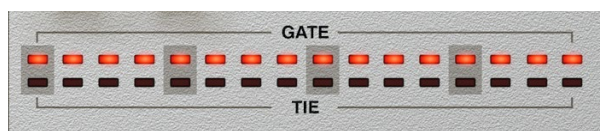

Gate and Tie step values

The diagram below shows an example of how settings of the **Arpeggiator Gate** and **Tie** rows correspond to sequences of **Arp Gate** and **Arp Tie Sources** in the **Modulation Matrix**:

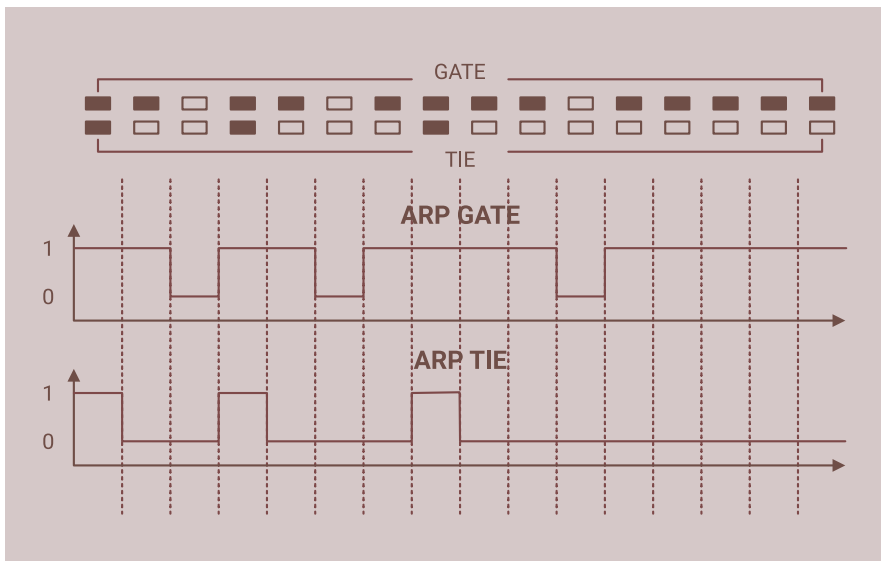

Modulation Matrix - Arp output example diagram

Note: **Arp Gate** and **Arp Tie Sources** work even if the **Layer Arpeggiator** is turned off (**Arpeggiator Mode** parameter set to **Off**). Regardless of whether the **Arpeggiator** is turned on or off, the tempo of the generated sequence is controlled by the **Rate** parameter in the **Arpeggiator** section.

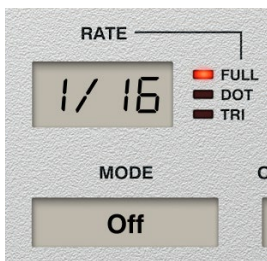

Arpeggiator - Rate and Mode

Velocity curve

Next to the **Modulation Matrix** table, you can find the **Velocity Curve** selector:

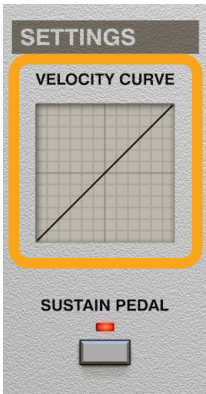

The Velocity Curve selector

This allows you to select between seven different dynamic curves to be taken into account in the **Modulation Matrix** (**Velocity Source**).

- Convex 3
- Convex 2
- Convex 1
- Linear
- Concave 1
- Concave 2
- Concave 3

Linear is selected as default.

Sustain pedal mode

Below, you can find the **Sustain Pedal** toggle button:

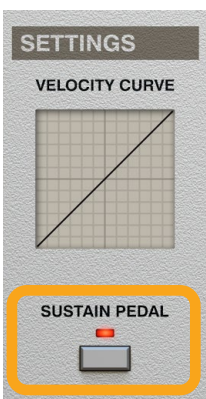

The Sustain Pedal mode switch

Apart from its basic task of sustaining the played notes, the **Sustain Pedal** can also be used as a **Source** in the **Modulation Matrix**. Therefore, we might want to disable the effect of the sustain pedal for played notes, limiting its influence to the **Modulation Matrix** only. It is possible to perform this action using the **Sustain Pedal** mode switch pictured above, which has two modes of operation:

- **Disabled** - (Note not sustained) Sustain pedal works in the **Modulation Matrix** only.
- **Enabled** - (Note sustained) Selected by default; sustain pedal fulfills its basic function and sustains played notes when pressed and can also be used as a **Source** for the **Modulation Matrix**.

Pitch table

Switching to the **Pitch Table** tab in a **Modulation Matrix** will bring up the **Pitch Table** editor:

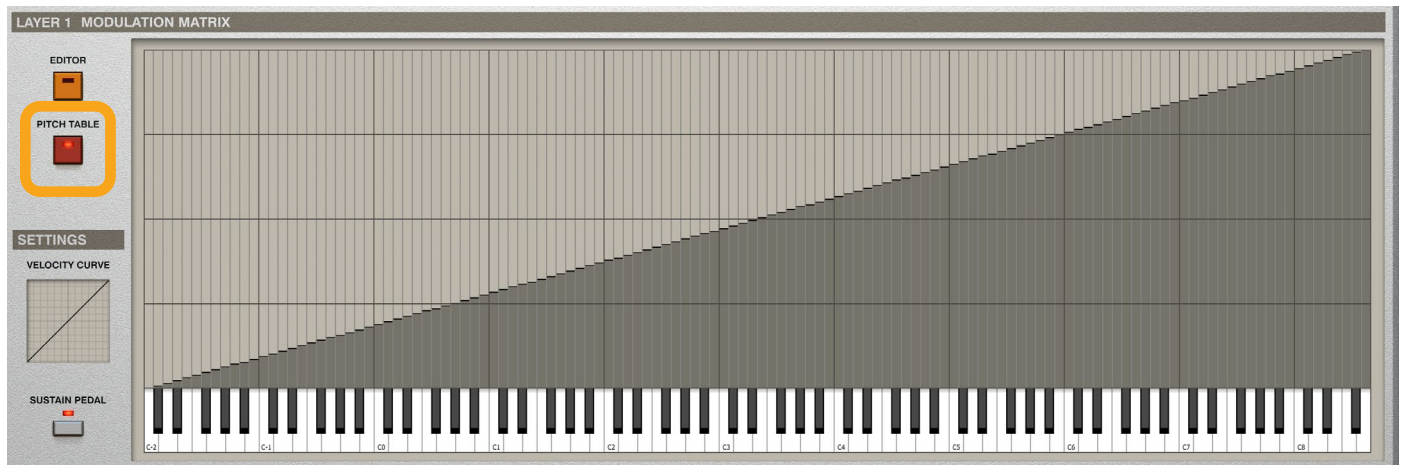

The *Pitch Table* tab

There is a graph situated in the **Pitch Table** tab that assigns a certain value in the range of $[0 - 100\%]$ to each MIDI Note coming into the **Layer**. This set of values is used in the **Modulation Matrix** as the **Source: Pitch Table**.

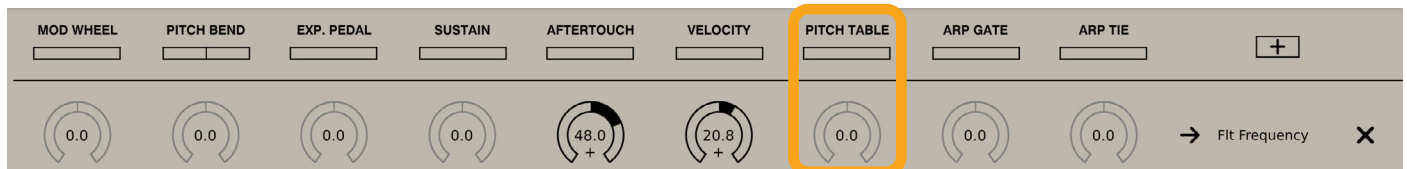

The *Pitch Table* column in *Modulation Matrix* sources

Depending on the MIDI Note received by **Lush 2**, a corresponding value is returned as a **Pitch Table** value in the **Modulation Matrix**.

Editing the **Pitch Table** values can be performed in two ways:

- **Freehand drawing** using the mouse while holding the left button.
- **Linearly interpolated drawing** using the mouse and clicking the right button. The first click starts a line and a successive click starts another line at the end of the first one, and so on. If you are done, just finish with a left mouse click.

Mixer

In **Lush 2**, we have **8 independent Layers**; each of them is actually an independent synthesizer with its own set of parameters, completely separated from the others. You can combine and mix the sound from all the **Layers** together in the **Mixer** view.

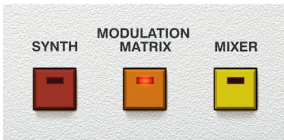

The View selector

After clicking the **Mixer** button, the **Mixer** view appears on the front panel of **Lush 2**:



The Mixer view

The first **8** channel strips represent the synthesizer **Layers**. The three following channel strips are the effect (**FX**) channels with three send effect algorithms permanently assigned to them (one each):

- **Reverb**
- **Delay**
- **Chorus**

Each of those send effects has its own set of parameters and a preset management system.

Each **Mixer** channel (**Layer** or **FX**) can be routed to one of the eleven available plug-in outputs.

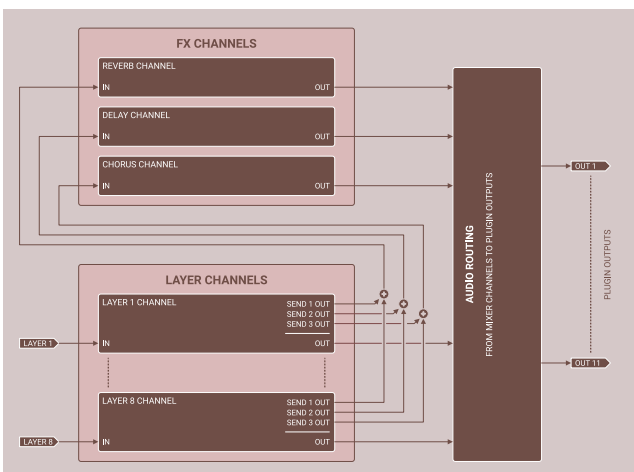

A diagram showing signal flow through the Mixer

Layer channel strip

Before the outgoing signal from a **Layer** is mixed with signals from other **Layers**, it passes through a channel strip.

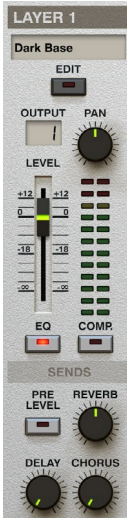

Mixer - a Layer's channel strip

Starting from the top of the channel strip, we can distinguish the following controls:

- **Display with Layer preset name** - Displays the name of the loaded **Layer** preset. Clicking the display opens a browser to load, save and manage presets (more on that in the **Preset Management** part of the manual).
- **Edit** - Opens a panel with additional parameters for the strip.
- **Output** - Selects the output channel the **Layer's** outgoing signal is routed to after processing.
- **Pan** - Controls a **Layer's** stereo balance.
- **Level** - Controls the output volume of the channel strip; the adjacent VU meter shows current outgoing signal level.
- **EQ** - Enables or disables parametric EQ (hidden in the strip's **Edit** panel).
- **Comp** - Enables or disables a compressor (hidden in the strip's **Edit** panel).

At the bottom, in the **Sends** section of the strip, there are parameters to control the amount of signal that's sent to **FX** channels.

- **Reverb** - Sets the send value for the **Reverb** channel.
- **Delay** - Sets the send value for the **Delay** channel.
- **Chorus** - Sets the send value for the **Chorus** channel.
- **Pre Level** - Decides whether the signal sent to effect channels takes the **Level** fader into account.

Edit panel

Clicking the **Edit** button in the channel strip:



Accessing Edit panel

Opens up the **Edit** panel with additional parameters for the channel strip:



Strips' Edit panel

Here, we have parameters controlling a dedicated compressor and parametric EQ:

- **Compressor**
 - **ENV** - Selects one of the three available fixed envelopes using a radio group of three LEDs:
 - **Fast** - Fast attack, slow release.
 - **Mid** - Medium attack, medium release.
 - **Slow** - Slow attack, fast release.
 - **Ratio** - Selects one of three available fixed compression ratios using a radio group of three LEDs:
 - **1:2**
 - **1:4**
 - **1:10**
 - **Threshold** - Sets the compressor threshold.
- **Parametric EQ**
 - **Hi** - Sets high-shelf gain from -24 dB to $+24\text{ dB}$ for frequencies $\geq 8\text{ kHz}$.
 - **Mid Frq** - Sets position for the peak of middle frequency **EQ** from 100 Hz to 10 kHz .
 - **Mid** - Adjusts gain value for the peak of middle frequency **EQ** from -24 dB to $+24\text{ dB}$.
 - **Low** - Sets low-shelf gain from -24 dB to $+24\text{ dB}$ for frequencies $\leq 100\text{ Hz}$.
 - **Pre Comp.** - Controls the sequence of processing by the **Compressor** and **EQ** sections. **Pre Comp.** has the following settings:
 - **Off** - The signal is processed first by the **Compressor** and then the **EQ**.
 - **On** - The signal is processed first by the **EQ** and then the **Compressor**.

Channel strip signal flow per layer

The diagram below depicts the signal flow through a channel strip:

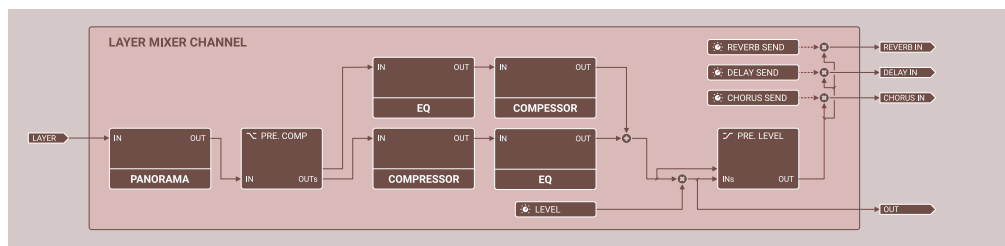

A diagram showing signal flow through a layer's channel strip

FX channel strips

Send knobs control the amount of signal from each **Layer** that is sent to each **FX** channel; they can be found in the **Sends** sections of **Layer** channel strips. The input of an **FX** channel is a sum of all parts from all sent **Layers**. Each **FX** channel is assigned to one effect algorithm (**Reverb**, **Delay** or **Chorus**) and then it goes through any further EQ or compression specific to the send.

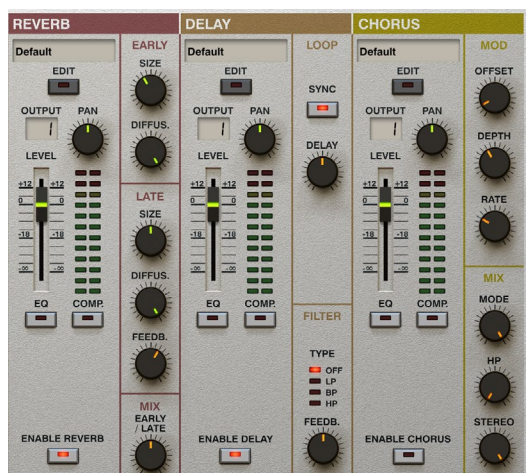

The 3 FX channel strips

The **FX** channel, apart from having an assigned effect algorithm, contains few other (common) elements affecting the sound:

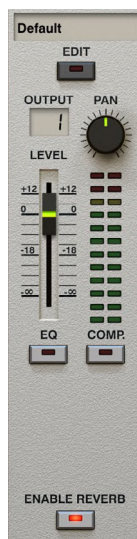

The common FX channel controls

- **Preset name** - Displays the name of the loaded preset for a particular effect (each **FX** channel has its own preset management system to store effect algorithm presets). Clicking the text box opens a browser to load, save and manage presets (more on that in the **Preset Management** part of the manual).
- **Edit** - Opens the **Edit** panel for the **FX** channel. In each strip, only the most commonly-used parameters are exposed. Opening the **Edit** panel shows all parameters available.
- **Output** - Sets the plug-in output number to route the **FX** channel output to (1 - 11).
- **Pan** - Panorama.
- **Level** - Controls the amplitude of the **FX** channel output signal.
- **EQ** - Enables and disables parametric **EQ** (hidden in the strip's **Edit** panel).
- **Comp** - Enables and disables the **Compressor** (hidden in the strip's **Edit** panel).
- **Enable [effect name]** - (The button at the bottom) Enables and disables the effect algorithm associated with a particular **FX** channel.

Edit panel

Clicking the **Edit** button in an **FX** channel strip:



Accessing Edit panel

Opens up an **Edit** panel with additional parameters for the channel strip:



Opening the Edit panel for an FX channel

The edit panel has two parts:

- **Specific** settings - Holds parameters associated with a particular **FX** channel strip. These settings vary from one channel to another.
- **General** settings - Holds parameters featured on all 3 **FX** channels, such as **EQ**.

The general part of an edit panel

In the general part of an **Edit** panel for **FX** channels, we can see the following set of parameters:



The common parameters in an Edit panel for FX channels

Here, we have parameters controlling a dedicated **Compressor** and parametric **EQ**:

- **Compressor**
 - **Attack** - Selects one of the three available fixed envelopes using a radio group of LEDs:
 - **Fast** - Fast attack, slow release.
 - **Mid** - Medium attack, medium release.
 - **Slow** - Slow attack, fast release.
 - **Ratio** - Selects one of three available fixed compression ratios using a radio group of LEDs:
 - **1:2**
 - **1:4**
 - **1:10**
 - **Threshold** - Sets the compressor threshold.
- **Parametric EQ**
 - **Hi** - Sets high-shelf gain from -24 dB to $+24\text{ dB}$ for frequencies $\geq 8\text{ kHz}$.
 - **Mid Frq** - Sets the position for the peak of middle frequency **EQ** from 100 Hz to 10 kHz .
 - **Mid** - Adjusts gain value for the peak of middle frequency **EQ** from -24 dB to $+24\text{ dB}$.
 - **Low** - Sets low-shelf gain from -24 dB to $+24\text{ dB}$ for frequencies $\leq 100\text{ Hz}$.
 - **Pre Comp.** - Controls the sequence of processing by the **Compressor** and **EQ** sections. **Pre Comp.** has the following settings:
 - **Off** - The signal is processed first by the **Compressor** and then the **EQ**.
 - **On** - The signal is processed first by the **EQ** and then the **Compressor**.

Reverb

The first FX channel is **Reverb**; its parameters are located in a strip on the right side of the channel.



The Reverb parameters in the FX channel strip

Only a handful of settings are exposed and the rest can be accessed by pressing the **Edit** button.

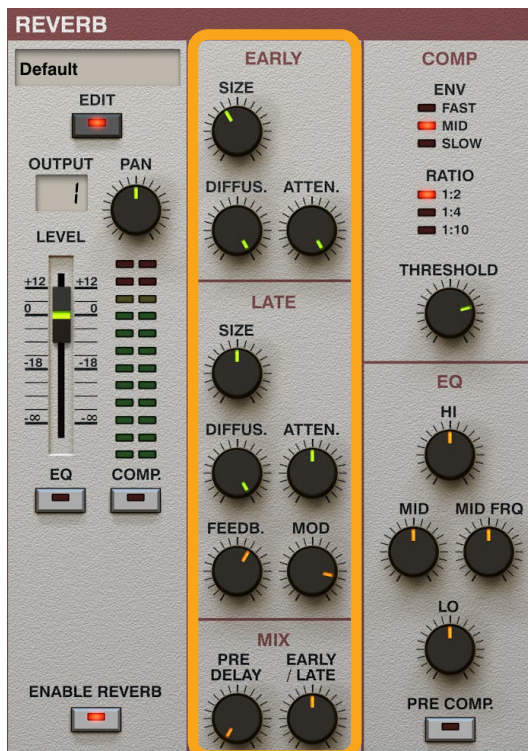

The Reverb parameters accessible from the Edit panel

Here, we can distinguish the following groups of parameters:

- **Early reflections:**
 - **Size** - Sets the room size for early reflections only.
 - **Diffusion** - Sets the reflecting surface's ability to spread the echo out. If this parameter is set to its lowest value, the reflecting surface is perfectly flat and does not distort the reflected wave. If set to its highest value, the reflecting surface distorts waves and spreads them out in different directions.
 - **Attenuation** - Changes the characteristic of the wall's surface - its absorption of high frequencies.

- **Late reflections:**
 - **Size** - Sets the room size for late reflections only.
 - **Diffusion**
 - **Attenuation**
 - **Feedback** - Controls how much wave energy is consumed by reflection. The smaller the value, the more energy is consumed, meaning the feedback is weaker.
 - **Modulation** - Controls the reverb delay lines' continuous variation.
- **Mix:**
 - **Pre delay** - Sets the delay between the dry signal and reverberation.
 - **ER / LT** - Cross-fades between early reflections output and late reflections output.

Delay

The second **FX** channel is **Delay**; its parameters are located in a strip on the right side of the channel.



The Delay FX channel strip

Only a handful of settings are exposed and the rest can be accessed by pressing the **Edit** button.

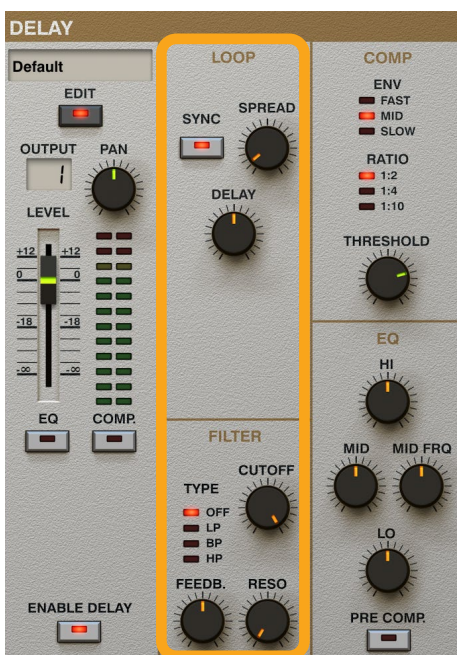

The Delay parameters accessible from the Edit panel

The following parameters control the **Delay** effect:

Loop section

Sync - Turns on/off synchronization with the host application. When off, the delay time is set by a **Delay** knob, otherwise it's set using the two LED displays (**Delay L** and **Delay R**):

- **Delay** - Sets the delay time in *milliseconds*. This control works only when **Sync** is turned off (non-tempo synchronized delay).
- **Delay L / Delay R** - Sets the delay by note values (relative duration), when in tempo synchronization mode (**Sync** turned on). We can set these values separately for *left* and *right* channels:

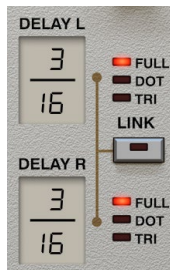

The tempo-based delay time panel

There are separate LED displays for both *left* and *right* channels (**L**, **R**). The numbers on the top are numerators; on the bottom - denominators. The entire fraction represents a note value, which is a delay time between the taps. The denominator is a rhythmic scale (e.g. 16 means it's a 16th note), the numerator is a multiplier; for example, 3/16 is a duration time of three 16th notes:

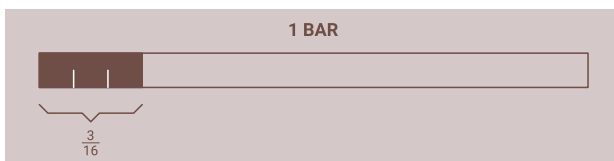

A 3/16th delay time diagram

- **Join** - Links both **Delay L** and **Delay R** controls.
- **Full / Dot / Tri** - Lets you select between three rhythmical modifiers according to each LED (for *left* and *right* channel independently):
 - **Full** - Full note,
 - **Dot** - Dotted note,
 - **Tri** - Triplet note.

Example: On the *left* channel, we set a delay value of 5/16; on the *right* channel, of 3/16. Additionally for the *right* channel, we select a **Dot** modifier. These are the resultant delays:

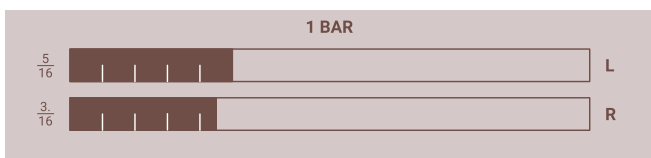

Delay - Example diagram

The function of the remaining parameters is as follows:

Spread - Sets a linear (additional) delay between the *left* and *right* channel. Therefore, if:

- **Sync is Off** - When the **Delay** effect is not synchronized with a host application, the maximum delay between the *left* and *right* channels is 50% of the **Delay** time knob value.
- **Sync is On** - When the **Delay** effect is synchronized with a host application, the maximum delay between *left* and *right* channels is 50% of the rhythmical value set in **Delay L**.

Filter section

- **Feedback** - Sets feedback value of the **Delay** effect.
- **Cutoff** - Sets the cutoff frequency of the filter in the delay loop.
- **Resonance**
- **Filter Type** - **OFF** (no filter), **LP** (low-pass filter), **BP** (band-pass filter), **HP** (high-pass filter).

Chorus

The third **FX** channel is **Chorus**; its parameters are located in a strip on the right side of the channel.



The Chorus FX channel strip

All **Chorus** parameters are accessible and none are hidden in an **Edit** panel. We can distinguish the following set of parameters:

- **Offset** - Sets the offset between the dry signal and the closest LFO oscillations controlling the delay lines, expressed in milliseconds.
- **Depth** - Sets the amplitude of **LFO** oscillations, expressed in milliseconds.
- **Rate** - Controls **LFO** frequency [0.01 Hz - 20 Hz]. The **LFO** waveform is triangular.
- **Mode** - Sets the volume of the second delay line, making the chorus sound fuller.
- **HP** - Controls high-pass filter cutoff frequency on the output from the **Chorus**.
- **Stereo** - This is the stereo phase offset of the **LFO** controlling the delay line.

Options

This chapter concerns all the additional plug-in settings that aren't stored with any preset type. These settings are exclusively stored within a DAW session but can also be saved and loaded using the options described later in this chapter.

MIDI and parameter automation

This chapter describes everything about communication between the DAW (host) and the plug-in regarding MIDI or parameter automation options.

MIDI

MIDI channels

MIDI messages from different channels can be sent to specific Layers in **Lush 2**. To set which MIDI channels each **Layer** within **Lush 2** responds to, just click the **Options** button and go to **MIDI -> Channels Setup**:

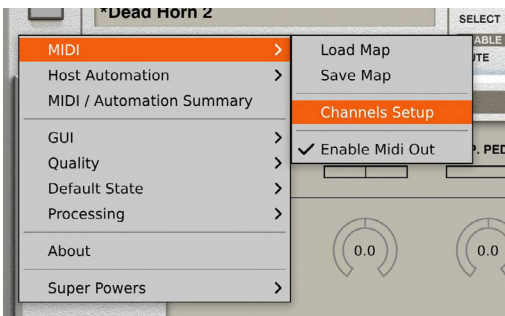

Opening the MIDI Channels Setup window

When you do so, the **Channels Setup** window will appear:

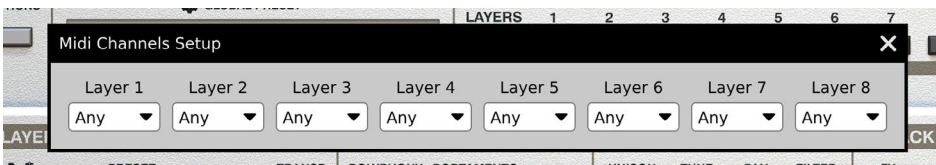

The MIDI Channels Setup window

Using combo boxes, you can choose whether a **Layer** should respond to **Any** MIDI channel or to a particular one (1-16). This setting is stored within a DAW project.

MIDI output

By default, **Lush-2** bypasses the MIDI messages it receives, meaning every MIDI event that goes into the plug-in is also sent out from the plug-in (which you can use to feed another MIDI track). If this functionality causes issues with your DAW (such as creating unwanted MIDI loopbacks) you can disable **Lush-2 MIDI Output** by clicking the **Options** button and unchecking the **MIDI -> Enable MIDI Out** option.

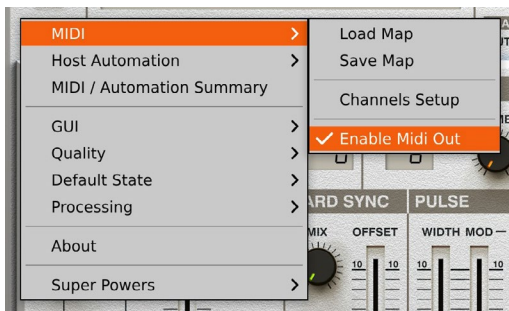

The Enable MIDI Out option

MIDI learn

Right-click any plug-in parameter to open the context menu:

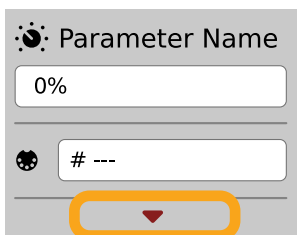

A context menu

Left-clicking outside the menu area closes it automatically.

Clicking the bottom arrow expands the menu and displays all available options:

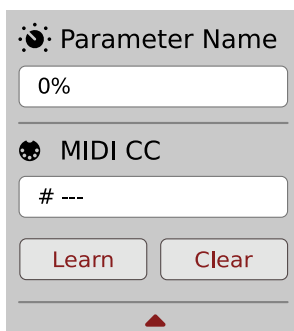

An expanded context menu

Linking a parameter to MIDI CC

The **Learn** function enables a quick assignment of physical controllers (from a MIDI controller) to plug-in parameters.

1. Click the **Learn** button to put the plug-in into a pending state before moving any MIDI CC controller.
2. Once the CC is recognized, click **OK** to save the change or click the **Cancel** button to restore the previous setting.

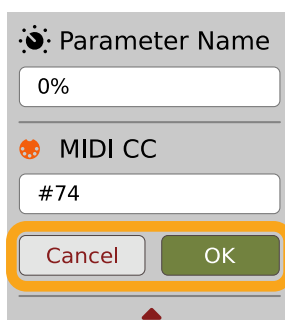

Linking a parameter to MIDI CC

Unlinking a parameter from MIDI CC

You can also delete a MIDI CC code attributed to a parameter from the context menu:

1. From the context menu, click the **Clear** button:

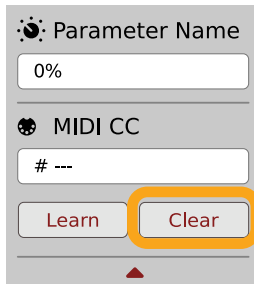

The Clear MIDI CC button

2. Then confirm using the **OK** button.

Loading / Saving a MIDI CC Map

These options are available in the **MIDI** submenu, accessible under **Cog** icon in the left-upper corner:

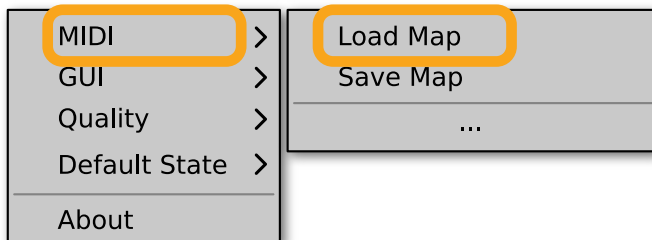

The Load Map and Save Map options

- **Save Map** - Saves the current MIDI CC map to a file.
- **Load Map** - Loads a MIDI CC map from a stored file.

Parameter automation

By default, all internal **Lush 2** parameters are disabled for external automation; this is because **Lush 2** has thousands of sound parameters and VST/AU/AAX technologies don't allow so many automatable parameters.

If you right click on a parameter in the **Lush 2** UI, you will see a context menu that allows you to enable automation for a given parameter and control it externally:

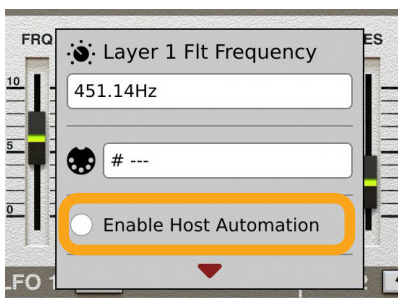

Enabling a parameter for automation

Note that not all parameters can be externally automated. Only parameters directly involved in sound generation have this option present.

Loading and saving an automation template

Once you enable the desired parameters for automation, you can save the automation map as a template to load later on in another plug-in instance.

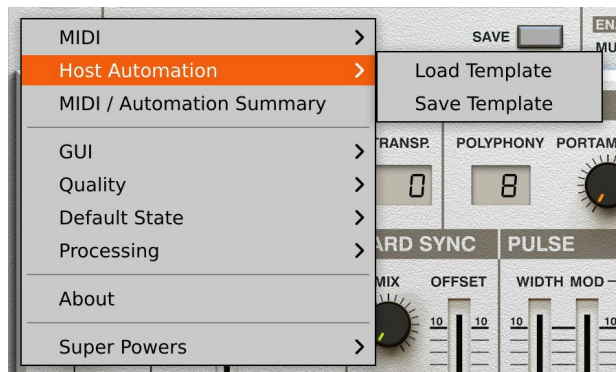

The Host Automation options

Click the **Options** button and go to the **Host Automation** menu to see the following options:

- **Load Template** - Loads an automation map from a file.
- **Save Template** - Saves current plug-in state as a new automation map file.

MIDI / automation summary

Once you have enabled some parameters for automation or assigned them (using **MIDI Learn**) to MIDI CC, you can check the current status of that assignment using **MIDI / Automation Summary** option in **Options** menu:

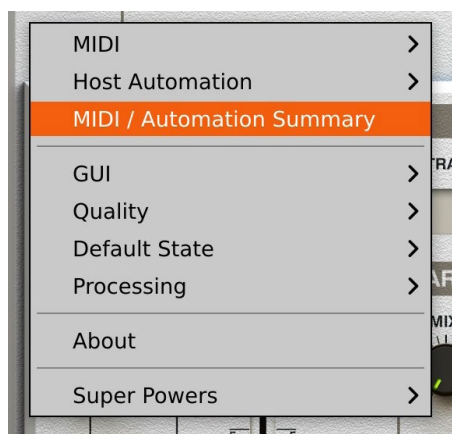

The MIDI / Automation Summary menu option

Using this option will bring up the **MIDI / Automation Summary** window:

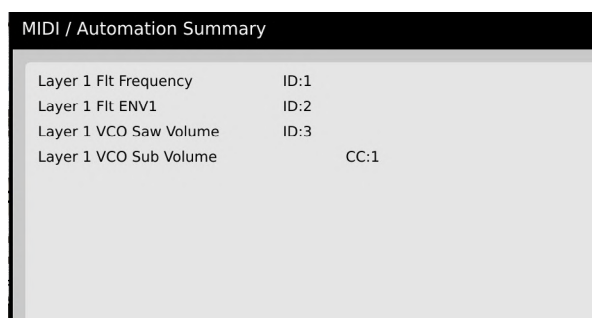

The MIDI / Automation Summary window

This shows the list of parameters enabled for automation (with the respective **IDs** they are assigned to) and/or the **MIDI CC** numbers they are assigned to.

GUI

The **Size**, **System Scale** and **Theme** options are accessible from the GUI submenu under the **Options** menu in the upper-left corner of the plug-in. With these, you can adjust the look of the plug-in to suit the pixel density and resolution of your screen, and make some tweaks to the look.

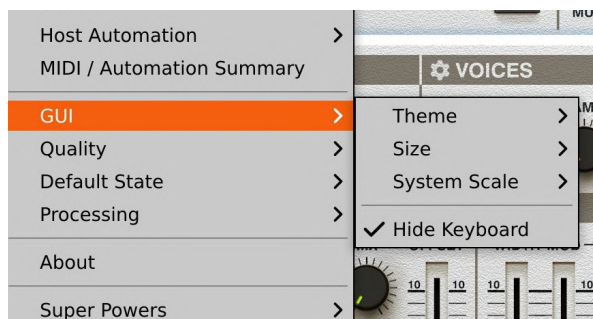

The GUI Size and look options

Size

This option lets you choose one of several default skin sizes to best match the plugin to the resolution of your computer monitor.

System Scale

System Scale controls the rescale factor for the whole plug-in. For the best visual results, you should set it to the exact value from your system settings (screen properties).

Theme

The **Theme** allows you to choose skin color variant according to your preference

Hide Keyboard

The **GUI -> Hide Keyboard** option allows you to hide the music keyboard, which saves more space on the screen:



The Lush 2 music keyboard

Quality settings

The **Quality** submenu under **Cog** icon in upper-left corner allows to choose sound quality for **Real-time** or **Offline** modes.

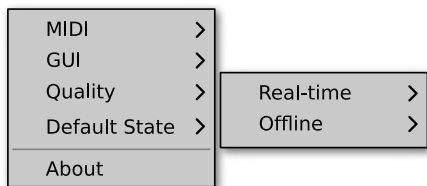

Quality settings

The higher the quality, the bigger the impact on the CPU.

Processing

Under the **Options** -> **Processing** submenu we can find two items:

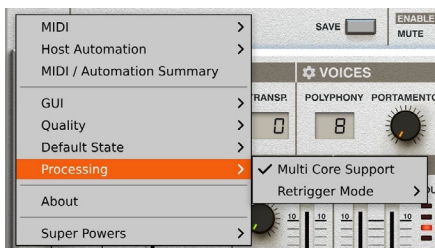

The Processing submenu in Options

- **Multi Core Support** - Increases performance on multi-core processors.
- **Retrigger Mode** - Decides how the **Reset** parameter works for **Envelopes** with monophonic sounds.

Multi core support

According to most plug-in format specifications, plug-ins process sound using a single thread unless multithreading is enabled in the host DAW. Plug-ins with a large demand for processor resources can significantly use it up, so **Lush 2** allows you to activate multi-core support; this lets the host DAW generate sound using the many processor cores available in most systems. Enabling the **Multi Core Support** option activates multi-thread processing in the plug-in and allows the available processor cores to evenly share the workload, removing bottlenecks in the general processor's use.

A multi-core processor is a necessary prerequisite for using this option, otherwise the processor's load may even increase.

Retrigger mode

This allows you to switch the envelope retrigger mode while **Polyphony = 1** (monophony) and within the envelope **Reset** mode on **Trig**.

- **Normal** - (Default) Every new MIDI note resets the **Envelope** even if previous notes are still sustained, as is characteristic of the **Trig Reset** mode. As **Polyphony = 1** voice, only one note is played; if we release a key and a previous note is still sustained through MIDI, the earlier note will be played but the envelope *will not* be reset.
- **SH-101** - This envelope retrigger mode was inspired by the manner in which the envelope worked in the **SH-101** synthesizer; if we release a key and a previous note is still sustained through MIDI, the earlier note will be played and the envelope *will* be reset.

Default settings

You can save your current settings so that the plug-in will default to them for each new instance, or restore the plug-in to load with its factory settings.

Changing default settings

1. Click the **Cog** icon in the left-upper corner of the plugin.
2. Go to the **Default State** submenu and choose the **Save current** option.

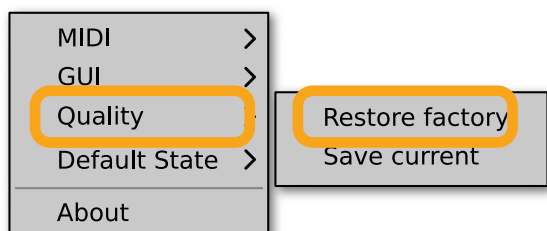

Changing the default state of the plug-in

With this option, the current plug-in state will be saved as the default / initial state for when you insert a new instance of the plug-in.

The plug-in state includes: sound parameters (default preset), views, preset filters, sound quality settings, loaded / created MIDI CC map and GUI settings.

Restoring factory defaults

To return the default state for new instances to factory settings:

1. Click the **Cog** icon in the left-upper corner of the plugin.
2. Go to the **Default State** submenu and choose the **Restore factory** option.

Preset management

Preset storage

Presets, both from **Factory** content and **User** ones, are stored as files in proper locations on the disc. Each time a plug-in instance is loaded into a project, these locations are scanned and the presets found there are consolidated into a single linear structure (list) in the **Preset Browser**.

Preset structure

The presets structure in **Lush 2** is hierarchically organized; there are five kinds of presets, which store different groups of parameters.

- **Layer presets** - Stores the following parameters:
 - **Voices** section,
 - **FX Rack** section,
 - **Layer Out** section,
 - All parameters from the **Synthesis** section,



- **Modulation Matrix**,
 - **Arpeggiator**.
- **Arpeggiator Preset**
- **Reverb Preset** - Reverb settings in the **Mixer** tab.
- **Delay Preset** - Delay settings in the **Mixer** tab.
- **Chorus Preset** - Chorus settings in the **Mixer** tab.
- **Global Preset** - (also simply called **Preset**) stores the state of the whole synthesizer, including:
 - All layers (see the **Layer** preset),
 - **Mixer** settings and send effects,
 - **Master** volume,
 - **Global Preset Settings**:
 - **Transpositions** and keyboard **Zones** for all **Layers**.
 - **Arpeggio Sync Mode**.

In general, a **Global Preset** aggregates presets from all **Layers** + **Delay** preset + **Reverb** preset + **Chorus** preset + additional parameters.

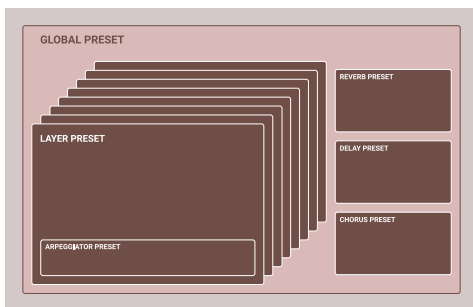

A diagram showing preset structure in Lush 2

Padlocks

Padlock is a functionality that lets you lock a certain set of parameters when a preset is loaded; values of locked parameters will not be altered. There are two kinds of **Padlocks** in **Lush 2**, with a different range of effect:

- Layer Padlock** - a **Layer Padlock** covers all **Layer** parameters (including the **Arpeggiator** in a particular **Layer**) and locks them only when loading **Global Presets**. This kind of **Padlock** will not work if we try to load a **Layer Preset** or an **Arpeggiator Preset**.



The Layer Padlocks

To activate **Padlocks** for selected **Layers**, click on the **Padlock** icons (in the **Control** section) that correspond to any **Layers** you want to lock. **Padlock** icons work in toggle mode.

- Arpeggiator Padlock** - This kind of **Padlock** covers all **Arpeggiator** parameters in a single **Layer** and locks them when loading **Layer Presets** or **Global Presets**, but it will not work on **Arpeggiator Presets**.

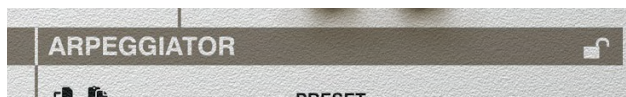

The Arpeggiator Padlock

To activate the **Arpeggiator Padlock**, use the **Padlock** icon in the **Arpeggiator's** top bar.

Browsing presets

The **Preset management section** (no matter what kind of preset it concerns) enables quick navigation and browsing of the preset structure:

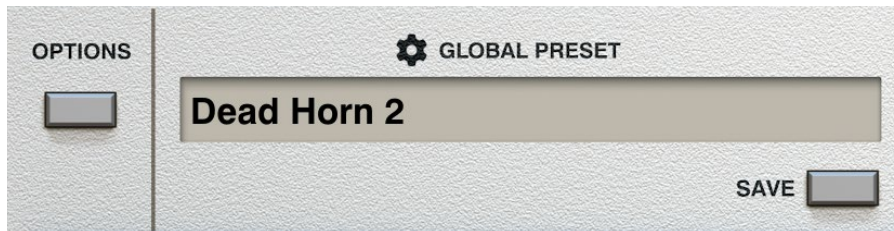

The Preset management section

- **PRESET** - Displays the name of the currently loaded preset. Clicking the display opens the **Preset Browser** panel, allowing you to browse factory / user presets.
- **Prev / Next** - Hovering over right side of the **Preset** display exposes the **Prev / Next** buttons:



They allow for linear browsing of the presets list (depending on currently set filters - see sections below).

- **Save** - Saves current parameters as a new preset or allows for overwriting of the existing one (see sections below).

Right-clicking over the **Preset** display opens a context menu with two or three additional options:

- **Init** - Restores initial settings of plug-in parameters.
- **Reload** - Reloads the most recently loaded preset.
- **Save** - See description above.

The **Preset Browser** looks as follows:

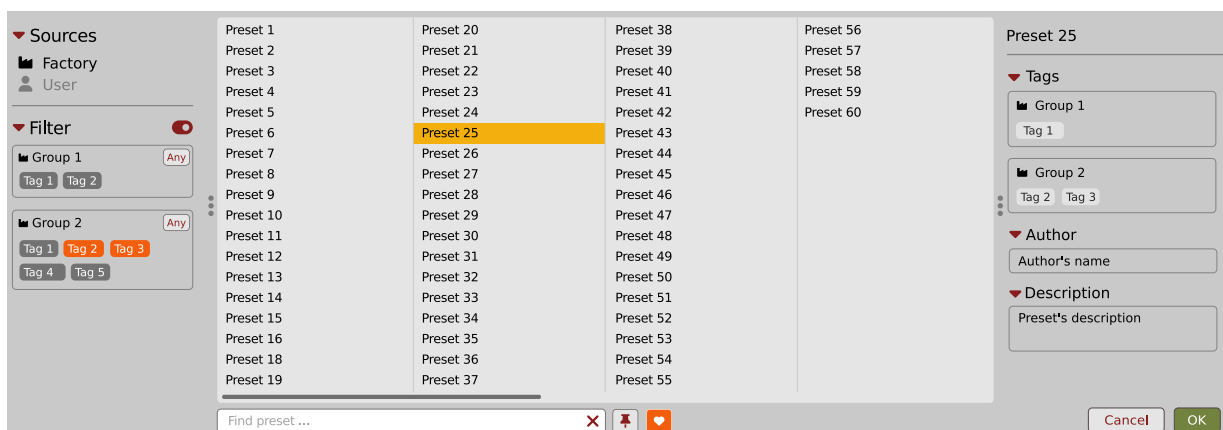

The Preset Browser

There are four main parts:

- **Sources** - Situated in the left column, filter content **Sources** for displayed presets.
- **Filter** - Below **Sources**, a preset **Filter** that uses the **Tags** system.
- **Results** - List of presets (shown in the middle column) from **Sources** that meet criteria set in the **Filter**.
- **Info pane** - The right column shows information about the currently selected preset(s), divided into several subsections.

If available - For some preset types this button can be hidden and accessible from the contextual menu (accessible via right mouse-click on **Preset display**)
 If available

Sources

In this section, you can choose a **Source / Source(s)** that you want to browse presets from.

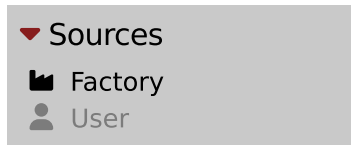

Preset Sources

There are two resources to choose from:

- **Factory** - Delivered together with the plug-in and cannot be modified (read-only).
- **User** - Created by the user and can be freely modified or shared with other users.

Choosing any of them will cause the results to narrow to the presets from one resource.

Filter

The section below is the **Filter**, which represents a preset filtering system using **Groups** and **Tags** to browse the content.

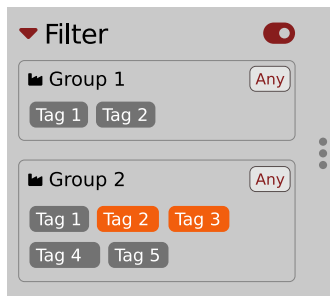

The Filter section

Groups and tags

Each **Preset** is described by a few common **Groups**. Within each of them there may be one or more **Tags** from a particular set.

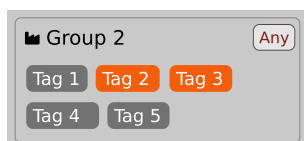

The Filter group

Presets from the **Factory** resource were assigned **Groups** and **Tags** when they were created.

Groups and **Tags** describe the content clearly, taking into account the plug-in's purpose.

Editing of the **Groups** and **Tags** for **Factory** content is limited. User presets can be described with the same **Groups** and **Tags** as **Factory** content, or you may define additional **Tags** within factory **Groups** and even create your own **Groups** with your own **Tags** to describe your own presets.

The only limitation is that a user cannot remove factory **Groups** or **Tags** from **Factory** content.

Results

This is a list of presets from chosen **Sources** that meet the filtering criteria. The basic function of this section is to browse and load presets. It can also be used for editing, which is described later.

Preset 1	Preset 20	Preset 38	Preset 56
Preset 2	Preset 21	Preset 39	Preset 57
Preset 3	Preset 22	Preset 40	Preset 58
Preset 4	Preset 23	Preset 41	Preset 59
Preset 5	Preset 24	Preset 42	Preset 60
Preset 6	Preset 25	Preset 43	
Preset 7	Preset 26	Preset 44	
Preset 8	Preset 27	Preset 45	
Preset 9	Preset 28	Preset 46	
Preset 10	Preset 29	Preset 47	
Preset 11	Preset 30	Preset 48	
Preset 12	Preset 31	Preset 49	
Preset 13	Preset 32	Preset 50	
Preset 14	Preset 33	Preset 51	
Preset 15	Preset 34	Preset 52	
Preset 16	Preset 35	Preset 53	
Preset 18	Preset 36	Preset 54	
Preset 19	Preset 37	Preset 55	

The Results list

- **Click** any name to choose and load the preset.
- **Double-click** the name to choose, load the preset and close the browser.

Hitting the **OK** button confirms loading a preset and closes the browser. Using **Cancel** closes the browser but reverts all parameter changes that loading a new preset might have caused.

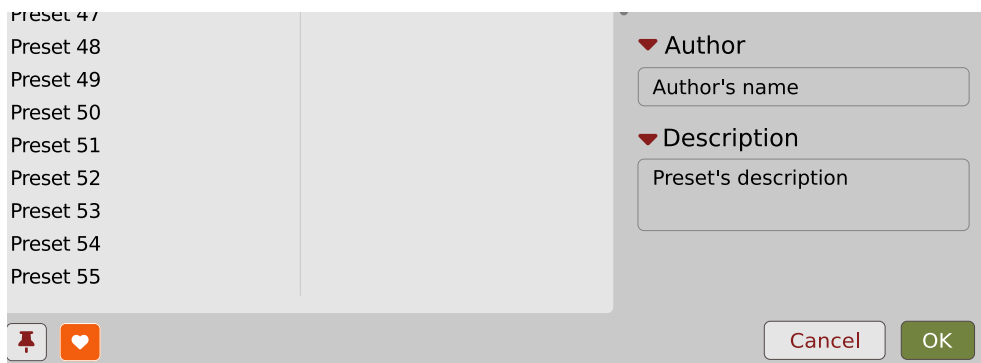

The OK and Cancel buttons in the browser

Using the **X** icon has the same effect as the **OK** button:

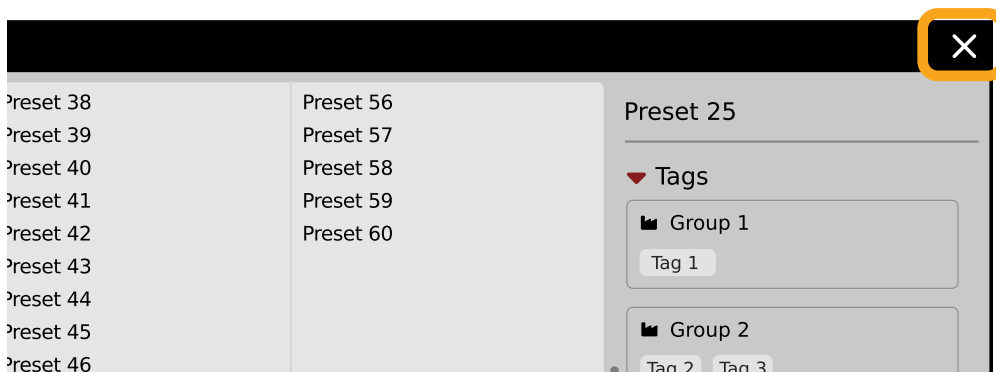

Close Browser window

Preset filtering using Groups and Tags

The **Filter** section contains **Groups** of **Tags**. Each Group is represented by a rectangle with the **Group** name + set of **Tags** inside.

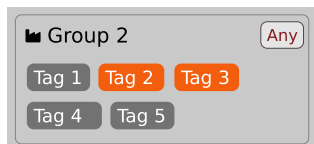

Group 2 with two tags set (Tag 2 and Tag 3)

The filtering process cascades from top to bottom. This means that all presets available in the selected **Sources** are filtered by selected **Tags** from the first **Group** (uppermost one), then the **Group** below and so on, until filtered by the last active **Group** (the bottom one).

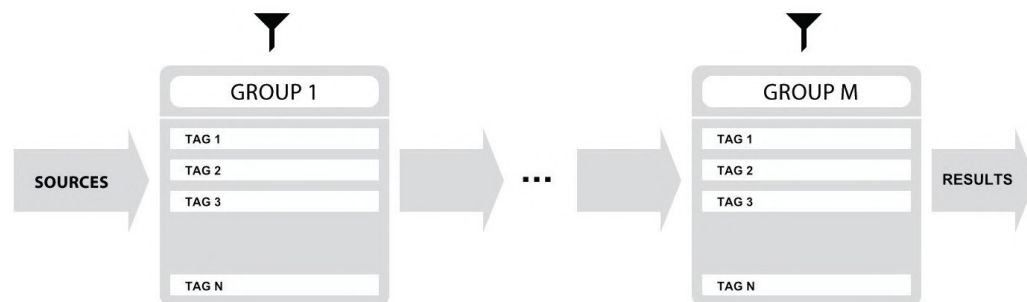

Preset Filtering with the use of Groups

The result of the cascade filtering process is listed in the middle column, the **Results** / presets list section. You can also consider the **Results** list as an intersection of preset sets, found by filtering through every individual **Group**.

Basic Actions

Tags work as toggle buttons. Click to *activate* / *deactivate* a **Tag**; a gray background color means that the **Tag** is inactive, and orange means that the **Tag** is active.

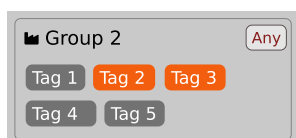

Group 2 with two tags set (Tag 2 and Tag 3)

If at least one **Tag** in a **Group** is active, then the **Group** (filter) also becomes active, otherwise the **Group** chosen doesn't affect the filtering process at all.

Group operator

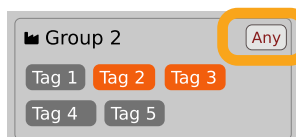

When a single **Tag** is active in a **Group**, only presets having that **Tag** set are displayed in the **Results**.

If two or more **Tags** in a **Group** are active, the **Results** depend on the **Operator** chosen for the **Group**:



A Group operator

The **Operator** button works in toggle mode and offers a choice of two alternative **Operators** for the **Group**:

- **Any**  - Means that a preset is shown in the **Results** when the preset includes at least one of the active **Tags** from the **Group**.
- **All**  - Means that a preset is shown in the **Results** only when the preset includes all active **Tags** from the **Group**.

Filter enable / disable

You can quickly enable / disable the **Filter** using the toggle switch in the top-most section of the **Filter**:

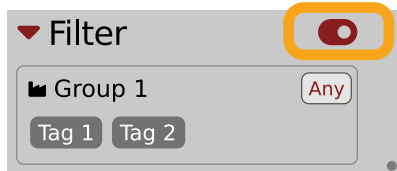

An On/Off switch for a Group Filter

Other types of filtering

Searching by name

Alternatively, you can look for a preset by entering its name or just a piece of its name into the **Find preset** field:



The Find preset input

The **Results** are refreshed on-the-fly and they work together with the other filters.

Using the **X** icon clears the entire field:





Clearing the search field

Filtering Favorite presets

You can mark presets as a **Favorite** by clicking the **Heart** icon while hovering on preset name . You can unmark presets by clicking the icon again (toggle mode):



Setting a preset as a Favorite on the list

-  Logical OR between Tags in the Group
-  Logical AND between Tags in the Group
-  It's allowed for every **source** (factory or user)

The flag is stored globally, meaning that a **Favorite** preset will be accessible as such from every other instance of the plug-in  .

Once you have your **Favorite** presets flagged, you can quickly filter them using the toggle button with a **Heart** icon on it:



Favorite presets filtering

If the button is active, then only **Favorite** presets will be shown (considering all remaining filters).

Filtering Pinned presets

You can **Pin** one or more presets using the **Pin** icon while hovering over a preset name  . You can unpin a preset by clicking the icon again (toggle mode):

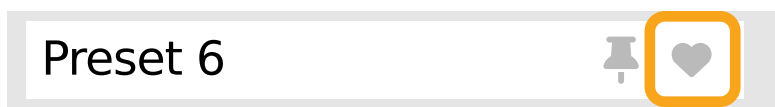

Pinning a preset on the list

Unlike **Favorites**, this flag works locally and it's stored with the project file (not global config), so **Pins** are stored individually for every instance (with total recall, so a plug-in state is recalled if saved in the context of a project).

But, similarly to **Favorites**, you can easily filter presets using the toggle button with the **Pin** symbol on it:



Pinned presets filtering

If the button is active, then only **Pinned** presets will be shown (considering all remaining filters).

Info pane

The column to the right shows information about the selected preset or presets. It also provides access to some of the preset editing functions.

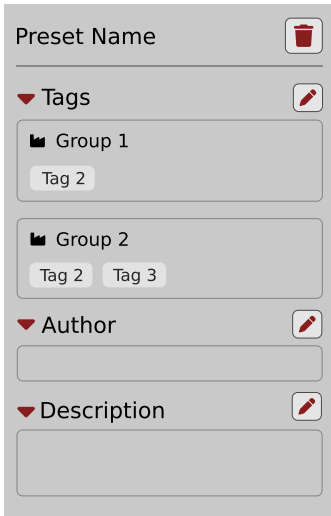

The Info pane

There's a preset name at the top.



The Preset name in the Info pane

Additionally, if you've selected more than one preset there's information about how many more have been selected:

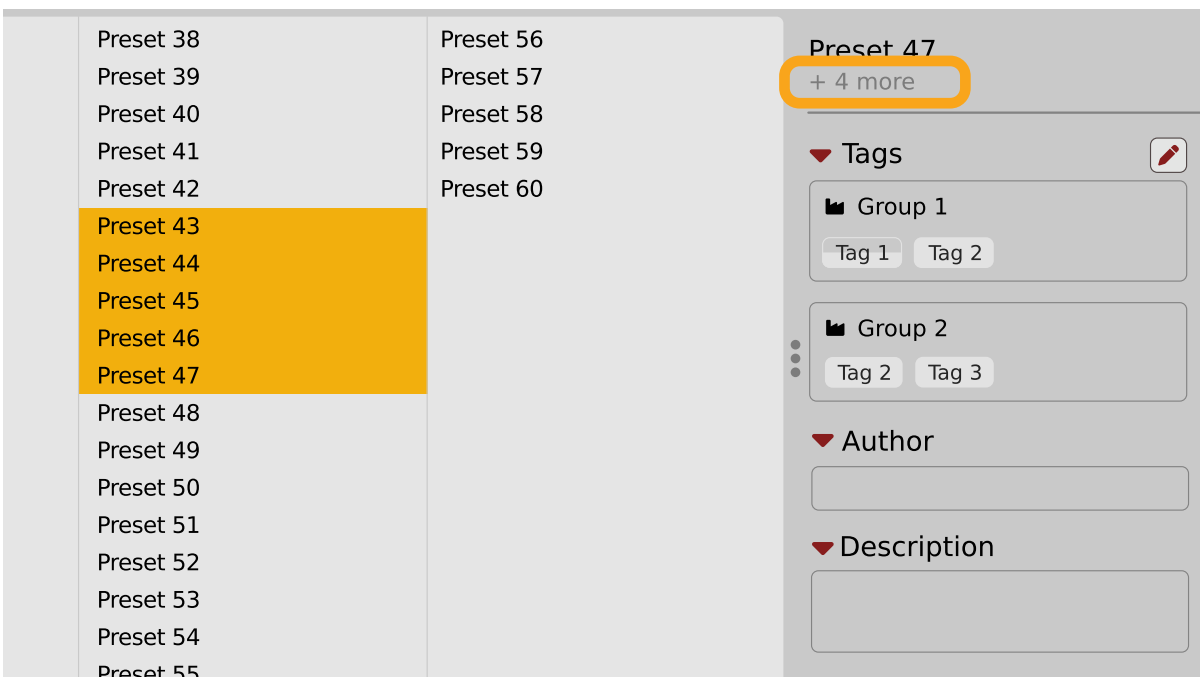

Selecting more than one preset

Below the preset(s) name there are few common sections describing selected presets:

- Tags
- Author
- Description

Browser's visual adjustments

Folding sections

If you don't need to see the contents of every section / subsection, you can fold some of them up using the **Caret** icons:

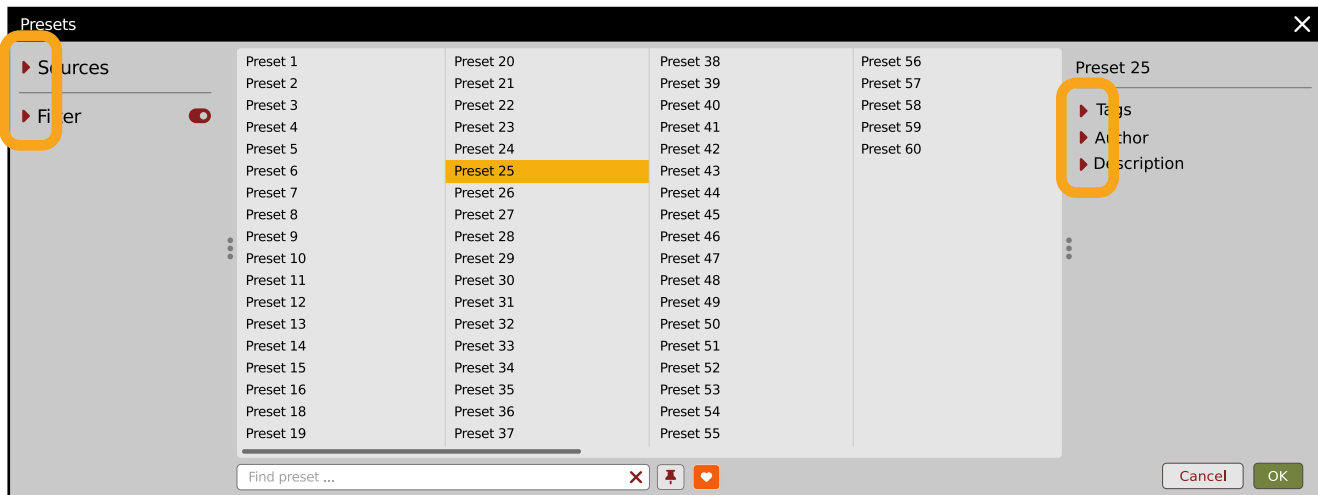

Sections folded up

Resizing columns

You can use the three-dotted handles to change a column's width to your preference.

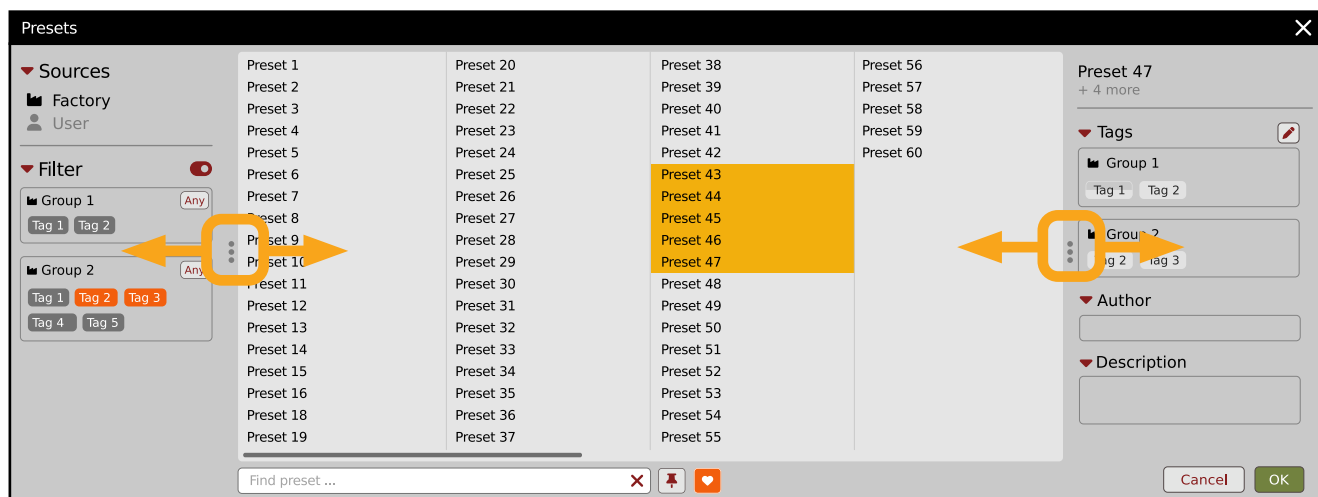

Resizing Browser columns

Editing presets

You can perform certain actions on presets, such as adjusting **Groups** and **Tags**, deletion, renaming the presets as well as their export or import. One should bear in mind, however, that some operations are only allowed on user presets but not on **Factory** content.

Preset selection for Edit

Some operations can be done on more than one preset, so you're allowed to select more than one preset at once; in the **Results** section, you can choose a preset or a set of presets in the following ways:

- **Click a preset** - Selects (and loads) one preset from the list.
- Win (**Ctrl**) + **Click the preset**), Mac (**Cmd**) + **Click the preset**) - Adds another preset to an already chosen preset or a set of presets.
- **Shift + Click the preset** - Selects a range of presets from the last chosen preset to the preset clicked with the *Shift* key.
- Right-Click on any **Preset** in the **Results** section and choose the **Select All** option - this selects all presets:

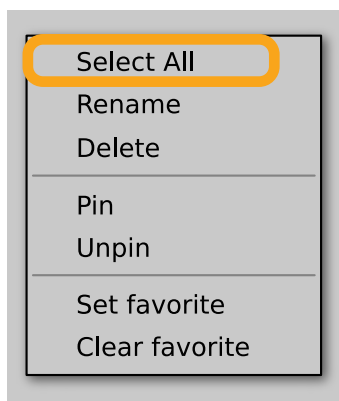

Selecting all presets

Preset renaming

On a selected preset , right-click to open the context menu and select the **Rename** option:

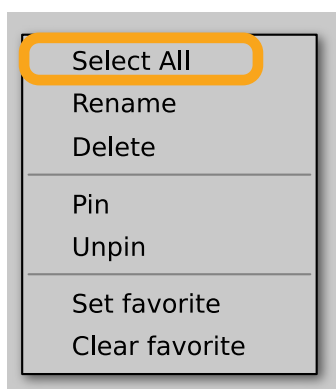

Preset renaming

▣ The option is available only for individual presets and won't work on a selection of two or more presets.

Preset deletion

Once you have selected one or more presets, right-click to open the context menu and select the **Delete items**  option:

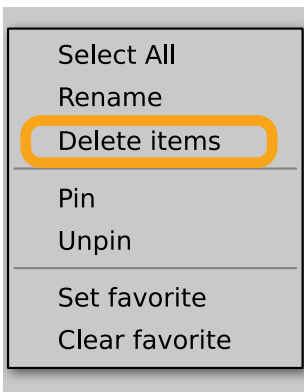

Deleting presets

Alternatively, you can use the **Trash bin** button in the **Info pane** to delete selected presets:

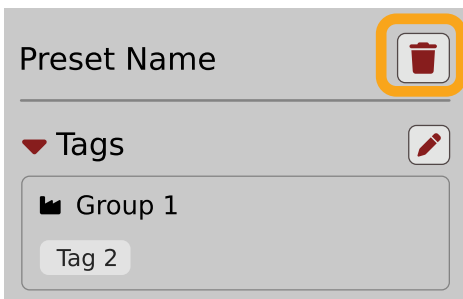

The Trash bin button

Tags editing

When you select a preset or presets to change their tags, click the **Pencil** button next the **Tags** section in the **Info pane** to enter **Edit mode** for the **Tags**:



Entering the Tag edit mode

 Or **Delete** option (depending on how many presets have been selected).

With the **Edit mode** enabled, you will see all possible **Groups** and **Tags** available for the preset(s):

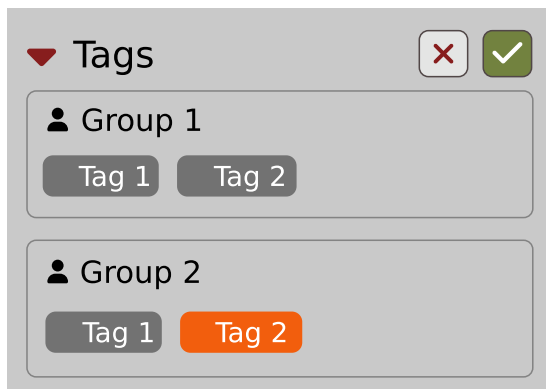

The Tag Edit mode

Tag buttons work in toggle mode, much like filtering. Clicking them either sets or erases a **Tag** for a chosen preset. If a **Tag** is set for a preset, it is indicated by an orange background color, whereas if a **Tag** is not set, it has a gray background color.

If you choose multiple presets with existing tags, **Tag** buttons will appear orange if a specific **Tag** appears in all selected presets, and gray if it appears in none.

When a specific **Tag** is set only for a few of the selected presets, it appears as half-gray and half-orange.

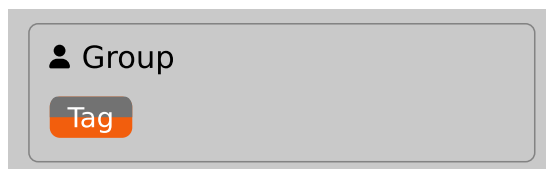

Tags appearing only in part of selection

Changing the **Tag** status for one or more chosen presets sets or erases this **Tag** in all these presets. A status change is signaled by an **Asterisk** to the left of a **Tag**.



A Tag with a status change

Tag buttons highlighted in half-gray and half-orange color (where **Tag** values across the highlighted presets aren't all the same) work in a three-state system when switching between states; they turn gray if you erase the **Tag** for all selected presets, orange if you set the **Tag** for all selected presets, and return to half-gray and half-orange if the selected items remain unchanged or are returned to their initial state.

Potential changes have to be confirmed using the **OK / Cancel** buttons at the top part of the **Tags** section:



Confirmation buttons in the Tags section

Author editing

When you select a preset or presets to change the **Author**, click the **Pencil** button next the **Author** section in the **Info** pane to enter the **Edit mode** for the **Author** field:

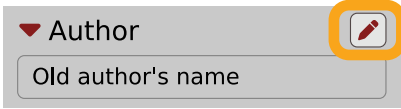

Editing Author

Once you've finished editing the field, confirm the operation using the **OK / Cancel** buttons:

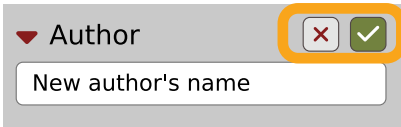

Confirming Author editing

This operation is possible for user content only.

Description editing

When you select a preset or presets to change the **Description**, click the **Pencil** button next the **Description** section in the **Info** pane to enter the **Edit mode** for the **Description** field:

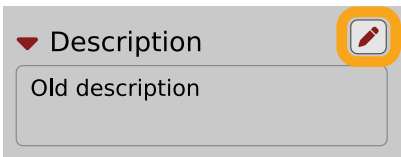

Editing Description

Once you've finished editing the field, confirm the operation using the **OK / Cancel** buttons:

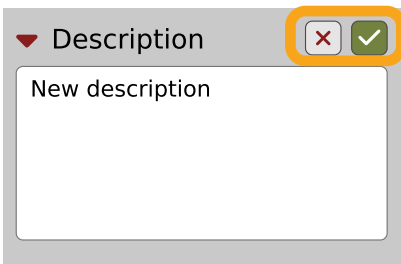

Confirming Description editing

This operation is possible for user content only.

Setting presets as Favorites

As described in the chapters above, you can mark a preset as a **Favorite** by clicking the **Heart** icon while hovering over the preset name:



Setting a preset as a Favorite

The flag is stored globally, meaning that a **Favorite** preset will be accessible as such from every other instance of the plug-in  .

It's also possible to perform the operation for a selection of presets. After you select the desired presets in the **Results** window, right-click on the presets to open a context menu:

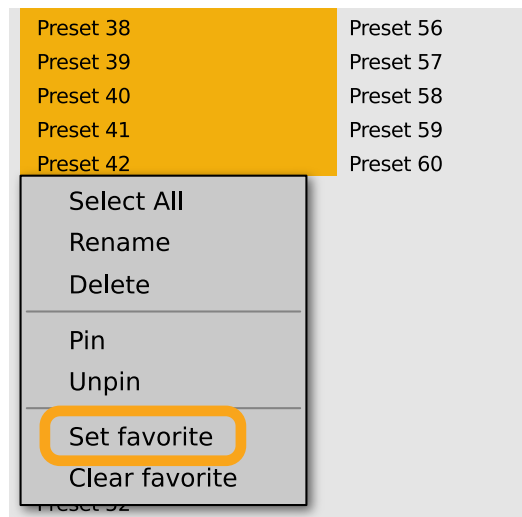

Setting Favorite presets from the context menu

And select the **Set favorite** option.

To clear **Favorite** flags for the selection of presets, use the **Clear favorite** option instead.

Pinning presets

You can **Pin** one or more presets using the **Pin** icon while hovering over the preset name:



Pinning a preset

Unlike **Favorites**, this flag works locally and it's stored with the project file (not globally). This means the **Pins** are stored individually for every instance (with total recall, so a plug-in state is recalled if saved in the context of a project).

 Sometimes a project or plug-in reload may be required

It's also possible to perform the operation for a selection of presets. After selecting the desired presets in the **Results** window, right-click on the presets list to open the context menu:

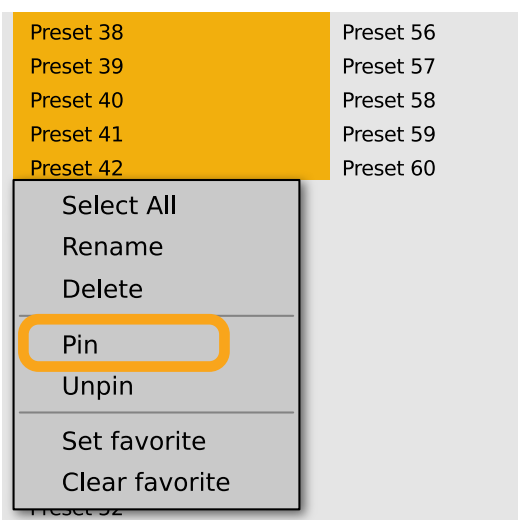

Pinning presets from selection

And select the **Pin** option.

To clear the **Pin** flag for a selection of presets, use the **Unpin** option instead.

Preset exchange

If you want to make a backup, or exchange a preset with a collaborator, you can export / import selected presets.

Export

Select a preset or presets that you're going to export and drag-and-drop them outside your DAW into a location you'd like to store them:

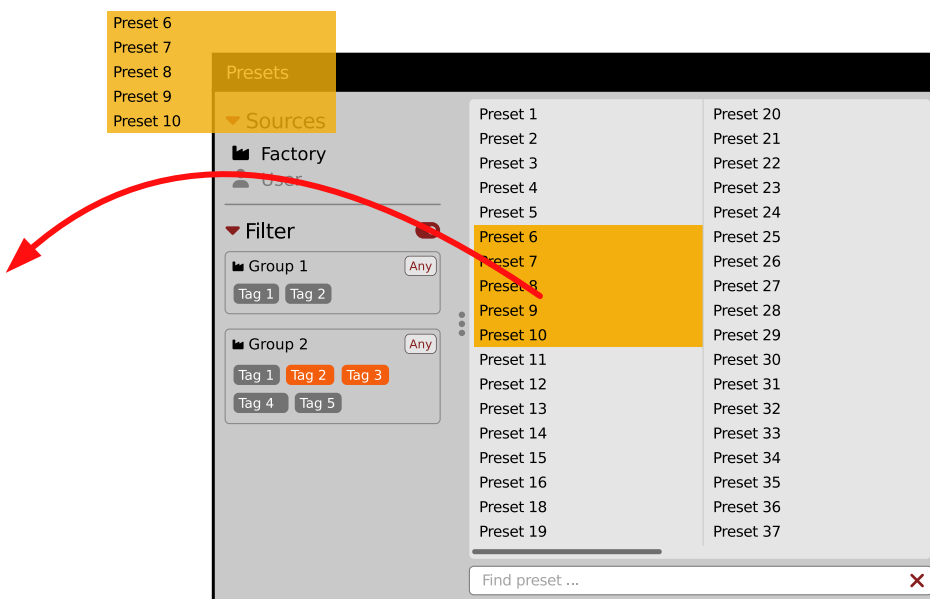

Exporting presets

The presets will be saved as individual files (one per preset) in the plug-in's native format.

Import

If you'd like to import preset files, you can drag-and-drop preset files from where they're stored, into the preset browser:

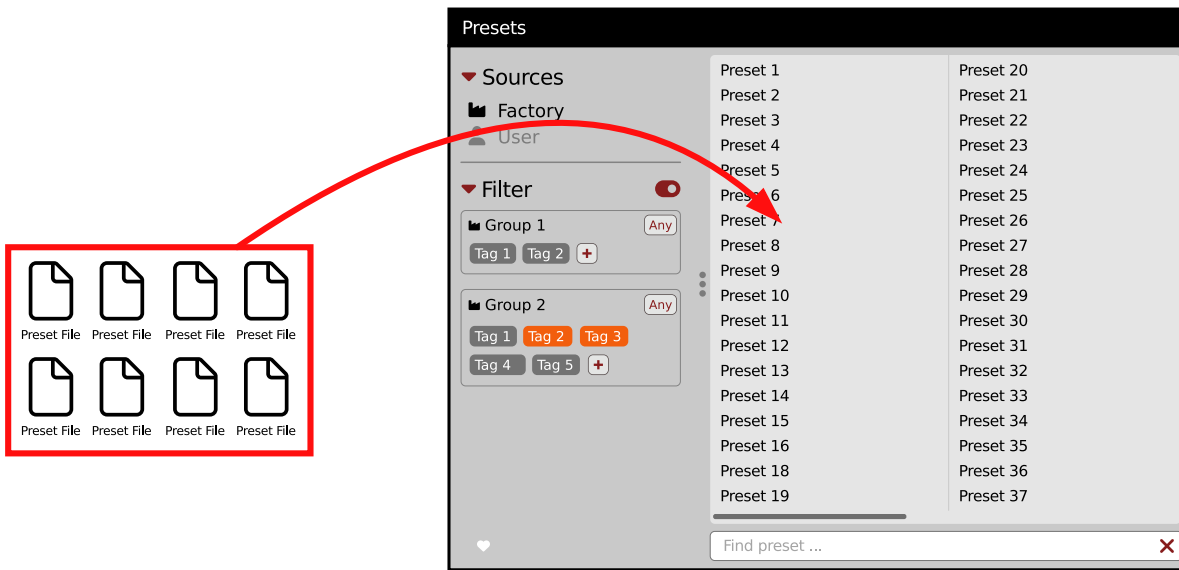

Importing presets

They will be automatically imported as user presets.

Creating custom Tags and Groups structure

Adding custom Tags

Users are allowed to add their own custom **Tags** to both their own content and factory content. To add a new **Tag** to an existing filter **Group**, click over the **Group's** name to pull down a menu and select the **Add Tag** option  :

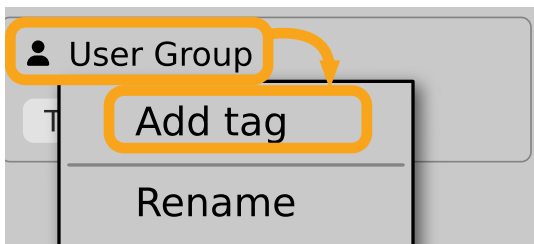

Adding a new Tag

You can do this either in the **Info Pane** (right column, while the **Tag edit** mode is enabled) or **Filter** (left column).

 This operation is allowed for a user's Groups only

Editing custom Tags

There are a few edit options available for a user to perform on their own **Tags**, which are available by right-clicking a **Tag's** name in the **Filter** section:

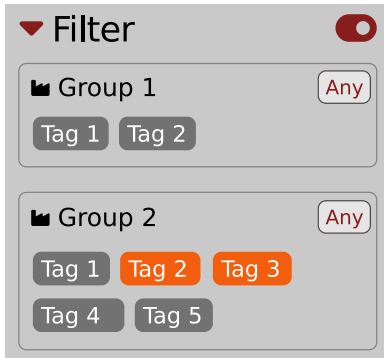

The Filter section

You will see a context menu with all the available options:

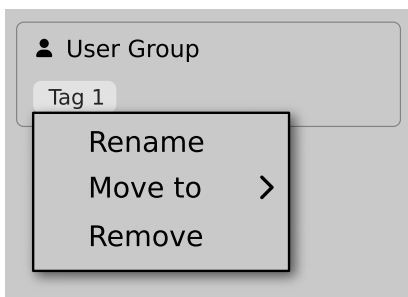

Editing options for a user Tag

- **Rename** - Changes the name of a **Tag**.
- **Move to** - Moves a **Tag** to another **Group**.
- **Remove** - Deletes a **Tag**.

The menu is accessible only for a user's own **Tags**.

Adding custom Groups

You can add a custom filter to **Groups** by clicking the **Filter** label and selecting the **Add Group** option from the pull-down menu:

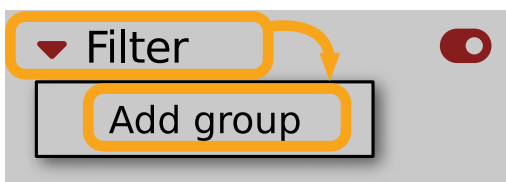

Adding a user Group

From here, you can add **Tags** to that newly created **Group** (see above), or move **Tags** from other **Groups**.

You can also add a custom filter to **Groups** in the **Info Pane** (right column) or **Filter** (left column).

Editing custom Groups

There are a few edit options available for a user to perform on their own **Groups**. Click on a **Group's** name in the **Filter** section:

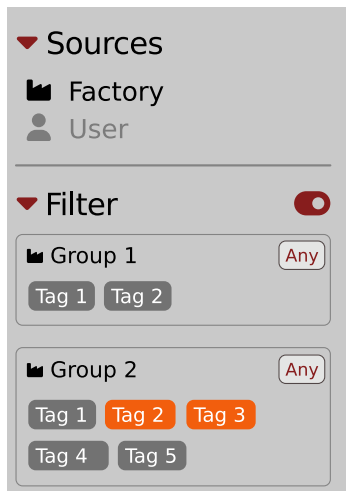

The Filter section

You will see a context menu with the following options:

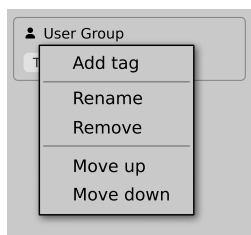

Edit options for a user Group

- **Add Tag** - Adds a new tag to the **Group** (described earlier).
- **Rename** - Changes the **Group's** name.
- **Remove** - Deletes the **Group**, possible only when all **Tags** in the **Group** have also been removed.
- **Move up** - Moves a **Group** up in the **Filter**. Possible unless the **Group** is already the topmost one.
- **Move down** - Moves a **Group** down in the **Filter**. Possible unless the **Group** is the last one.

These operations are possible only on user **Groups**.

Groups in the **Filter** are ordered with **Groups** from **Factory** content first, then user groups below.

You can edit user **Groups** in either the **Info Pane** (right column, while **Edit mode** for **Tags** is enabled) or **Filter** (left column).

Unassigned Tags

When you receive content from a collaborator who uses different **Tags** and **Groups**, some Tags may show as **Unassigned**. This happens if the filter structure made by a preset's author is different.

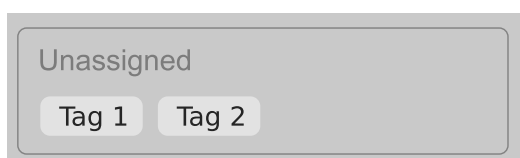

Unassigned Tags

You can move the **Tags** across your **Groups** to make them fit your scheme, or re-tag the collaborator content entirely.

Requirements.....	2	The general part of an edit panel.....	52
Preliminary information.....	3	Reverb.....	53
Introduction to Lush.....	5	Delay.....	54
Control section.....	7	Loop section.....	55
Options.....	7	Filter section.....	56
Global preset browser.....	7	Chorus.....	56
Layer selector.....	8	Options.....	57
View selector.....	8	MIDI and parameter automation.....	57
Master volume.....	8	MIDI.....	57
Global preset settings.....	8	MIDI channels.....	57
MIDI tab.....	9	MIDI output.....	57
Zone editor.....	9	MIDI learn.....	58
Zone learn.....	10	Linking a parameter to MIDI CC.....	58
Transposition.....	10	Unlinking a parameter from MIDI CC.....	59
Arpeggiator tab.....	11	Loading / Saving a MIDI CC Map.....	59
Layer parameters.....	12	Parameter automation.....	59
The layer's top bar.....	14	Loading and saving an automation template.....	60
Layer preset browser.....	14	MIDI / automation summary.....	60
Layer transposition.....	14	GUI.....	61
Polyphony and unison.....	14	Size.....	61
Polyphony settings.....	14	System Scale.....	61
Unison.....	15	Theme.....	61
Voice settings.....	15	Hide Keyboard.....	61
Sound synthesis.....	16	Quality settings.....	62
Oscillators.....	16	Processing.....	62
Oscillators mixer.....	17	Multi core support.....	62
Oscillator's independent Voltage Controlled		Retrigger mode.....	62
Amplifier (VCA).....	18	Default settings.....	63
The oscillators' waveform options.....	19	Changing default settings.....	63
SuperSaw.....	19	Restoring factory defaults.....	63
Suboscillator waveform.....	20	Preset management.....	64
Noise type.....	20	Preset storage.....	64
Oscillators' hard restart option.....	21	Preset structure.....	64
VCO settings.....	21	Padlocks.....	65
Pulse width modulation.....	22	Browsing presets.....	66
Hard sync.....	22	Sources.....	67
Envelope generators - ENV1 and ENV2.....	23	Filter.....	67
Reset.....	23	Groups and tags.....	67
Invert.....	24	Results.....	68
LFO1 and LFO2.....	25	Preset filtering using Groups and Tags.....	69
Tempo synchronization.....	26	Basic Actions.....	69
Reset.....	26	Group operator.....	69
Extra parameters.....	27	Filter enable / disable.....	70
Filters.....	28	Other types of filtering.....	70
Pitch parameters and modulation.....	30	Searching by name.....	70
Amplitude modulation - VCA.....	31	Filtering Favorite presets.....	70
Wheel and bend sections.....	32	Filtering Pinned presets.....	71
Insert effects.....	33	Info pane.....	72
Chorus.....	34	Browser's visual adjustments.....	73
Flanger.....	34	Folding sections.....	73
String ensemble.....	34	Resizing columns.....	73
Phaser.....	35	Editing presets.....	74
Vowel.....	35	Preset selection for Edit.....	74
Distortion.....	36	Preset renaming.....	74
Bit crusher.....	36	Preset deletion.....	75
Tremolo.....	37	Tags editing.....	75
Master section.....	37	Author editing.....	77
Arpeggiator.....	37	Description editing.....	77
Padlock.....	39	Setting presets as Favorites.....	78
Arpeggiation examples.....	40	Pinning presets.....	78
Modulation matrix.....	41	Preset exchange.....	79
Voice volume - a special destination parameter.....	43	Export.....	79
Arp gate, arp tie - special modulation sources.....	43	Import.....	80
Velocity curve.....	45	Creating custom Tags and Groups structure.....	80
Sustain pedal mode.....	45	Adding custom Tags.....	80
Pitch table.....	46	Editing custom Tags.....	81
Mixer.....	47	Adding custom Groups.....	81
Layer channel strip.....	48	Editing custom Groups.....	82
Edit panel.....	48	Unassigned Tags.....	82
Channel strip signal flow per layer.....	50		
FX channel strips.....	50		
Edit panel.....	51		